

SPEED

PROFESSIONAL PERFORMANCE

A 4", 6", 8", 10" series

Stainless Steel Submersible Pumps

50Hz



SPEED A Series

Index

General Data

Performance Range	2
Material Specification	3
4" Submersible Pumps	7
6" Submersible Pumps	8
8" Submersible Pumps	9
10" Submersible Pumps	10

Performance Curves/Technical Data

Series A 1	11
Series A 2	13
Series A 3	15
Series A 5	17
Series A 8	19
Series A 14	21
Series A 22	23
Series A 33	25
Series A 55	27
Series A 66	29
Series A 88	31
Series A 120	33
Series A 150	35
Series A 200	37
Series A 250	39

A Series 4", 6", 8", 10" Stainless Steel Submersible Pumps

A 4", 6", 8" and 10" submersible pumps are made of corrosion and abrasion resistant stainless steel and have been developed in accordance with state-of-the-art technology. The A series of pumps are manufactured to the highest standards for energy efficiency, dependable performance, rugged construction and long service life for the most demanding applications.

General Data

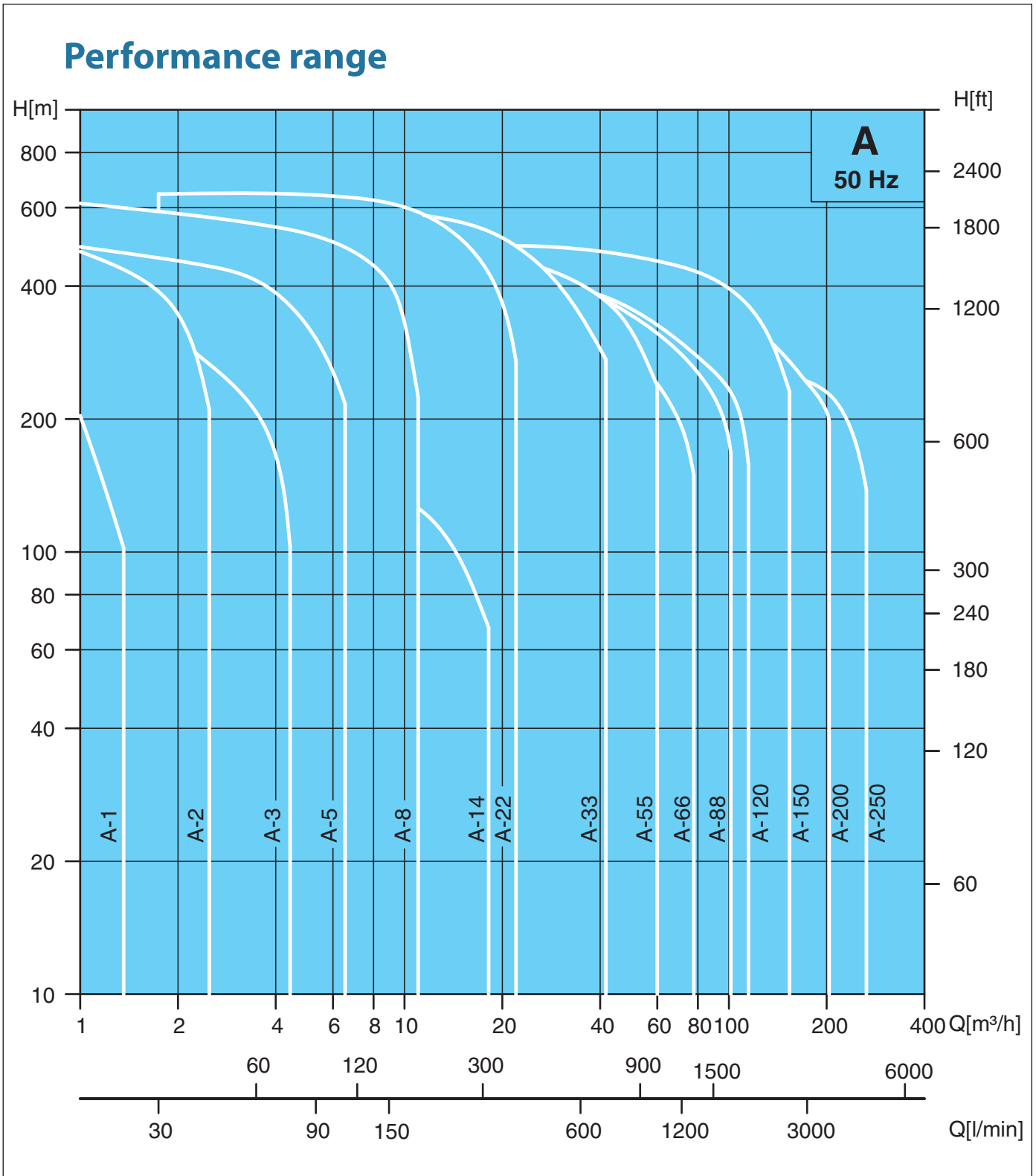

General Data

Example: A-14

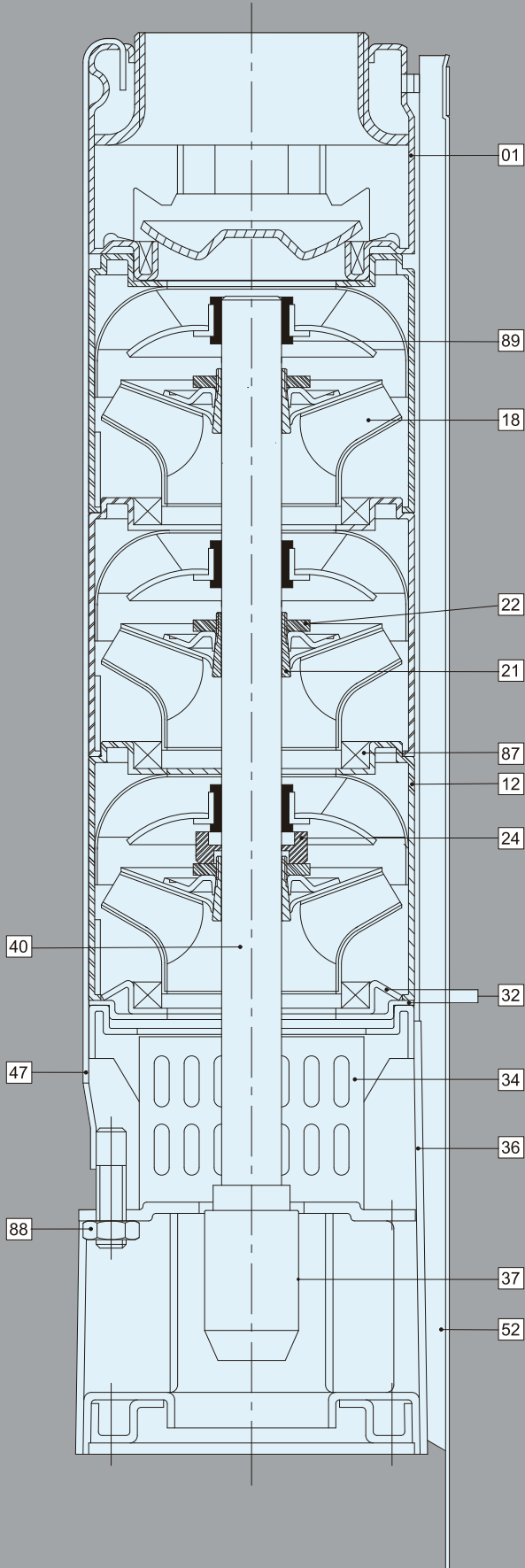

Material Specification-4" Pumps

Pos.	Components	Standard
01	Discharge	SUS304 / SUS316
12	Diffuser	SUS304 / SUS316
18	Impeller	SUS304 / SUS316
21	Split Cone	SUS304 / SUS316
22	Split Cone Nut	SUS304 / SUS316
24	Stop Ring	Carbon+Graphite+PTFE
32	Neck Ring Retainer	SUS304 / SUS316
34	Strainer	SUS304 / SUS316
36	Suction Interconnector	SUS304 / SUS316
37	Coupling	SUS304 / SUS316
40	Pump Shaft	SUS304 / SUS431 / SUS316
47	Strap	SUS304 / SUS316
52	Cable Guard	SUS304 / SUS316
87	Neck Ring	SUS304+NBR / SUS316+NBR
88	Nut	SUS304 / SUS316
89	Bearing	NBR

*AISI 316 stainless steel pumps are available on request.

General Data

Example: A-22

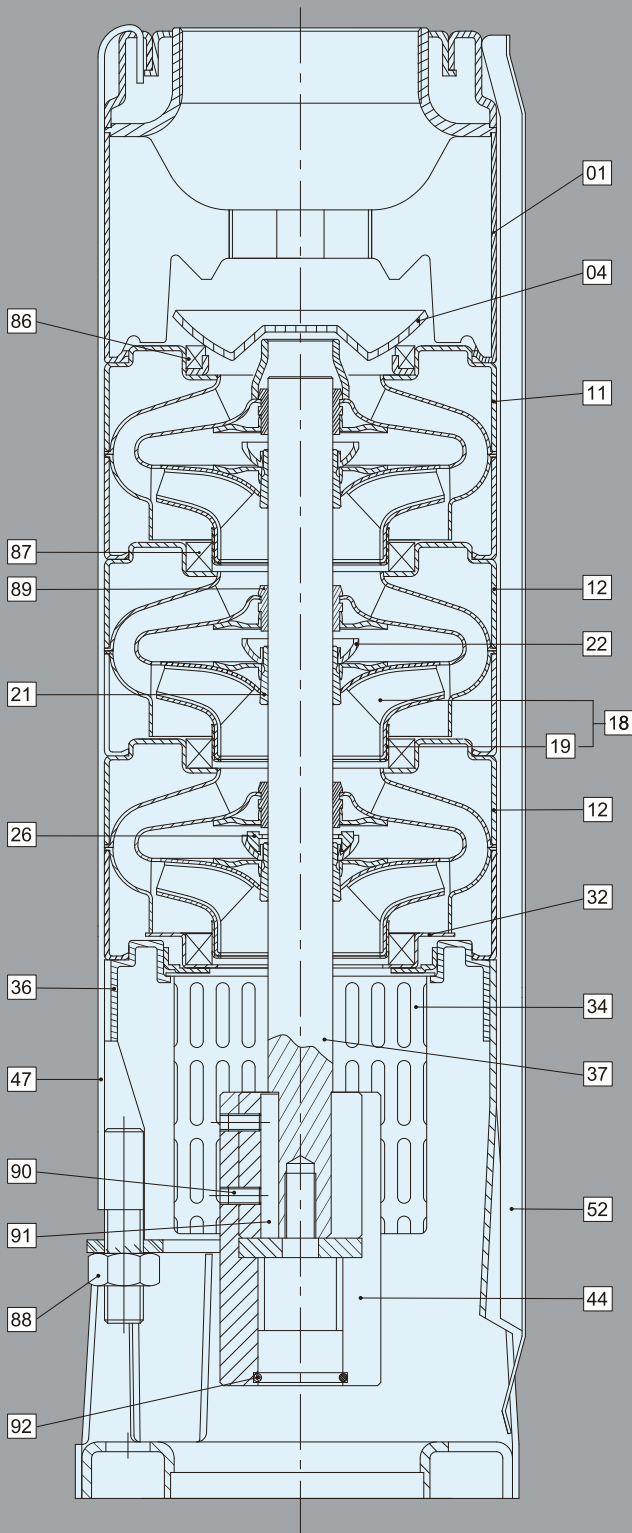

Material Specification-6" Pumps

Pos.	Components	Standard
01	Discharge	SUS304 / SUS316
04	Valve Cone	SUS304 / SUS316
11	Top Diffuser	SUS304 / SUS316
12	Diffuser	SUS304 / SUS316
18	Impeller	SUS304 / SUS316
19	Ring of Impeller	SUS304 / SUS316
21	Split Cone	SUS304 / SUS316
22	Split Cone Nut	SUS304 / SUS316
26	Spacing Washer For Stop Ring	Carbon+Graphite+PTFE
32	Neck Ring Retainer	SUS304 / SUS316
34	Strainer	SUS304 / SUS316
36	Suction Interconnector	SUS304 / SUS316
37	Pump Shaft	SUS431 / SUS316
44	Coupling	SUS431 / SUS316
47	Strap	SUS304 / SUS316
52	Cable Guard	SUS304 / SUS316
86	Valve Seat	SUS304+NBR / SUS316+NBR
87	Neck Ring	SUS304+NBR / SUS316+NBR
88	Nut	SUS304 / SUS316
89	Bearing	NBR
90	Screw	SUS304 / SUS316
91	Key	SUS304 / SUS316
92	O-ring	NBR

*AISI 316 stainless steel pumps are available on request.

General Data

Example: A-120

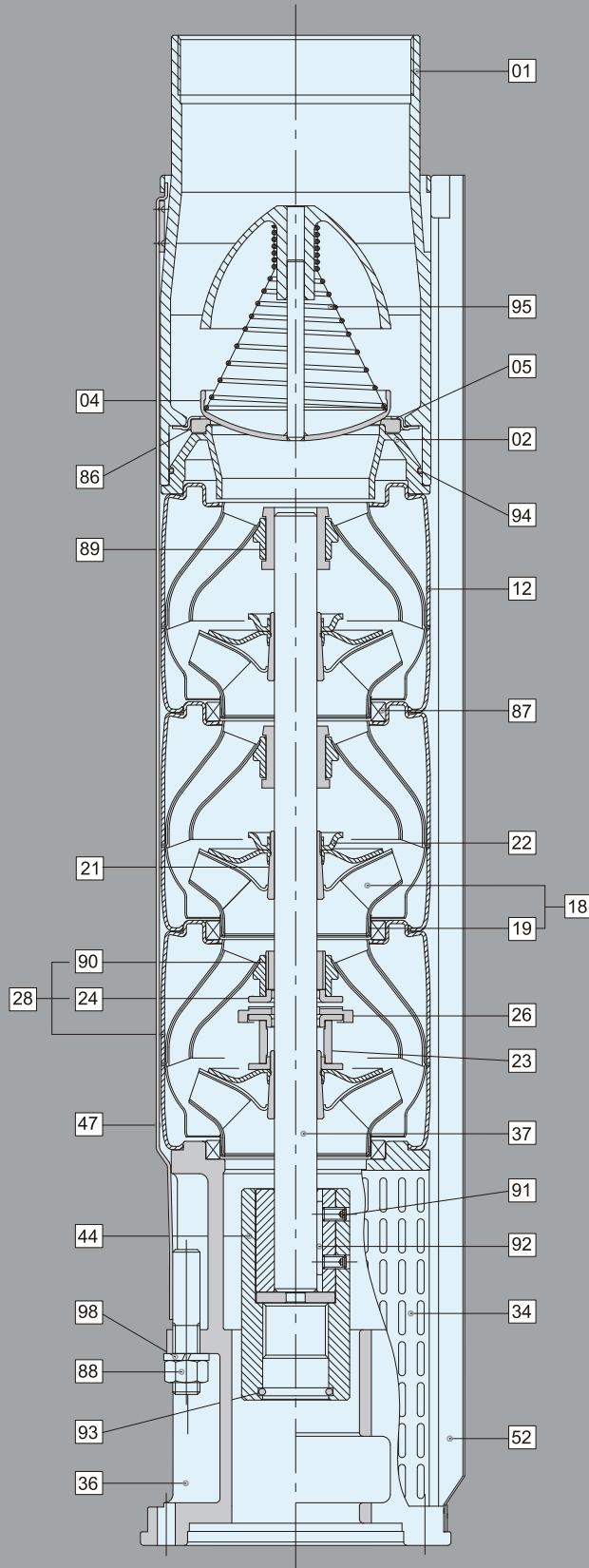

Material Specification-8" Pumps

Pos.	Components	Standard
01	Discharge	SUS304 / SUS316
02	Lower Valve Seat Retainer	SUS304 / SUS316
04	Valve Cup	SUS304 / SUS316
05	Upper Valve Seat Retainer	SUS304 / SUS316
12	Diffuser	SUS304 / SUS316
18	Impeller	SUS304 / SUS316
19	Ring Of Impeller	SUS304 / SUS316
21	Split Cone	SUS304 / SUS316
22	Split Cone Nut	SUS304 / SUS316
23	Nut For Stop Ring	SUS304 / SUS316
24	Stop Ring	SUS304 / SUS316
26	Spacing Washer For Stop Ring	Carbon+Graphite+PTFE
28	Bottom Diffuser	SUS304 / SUS316
34	Strainer	SUS304 / SUS316
36	Suction Interconnector	SUS304 / SUS316
37	Pump Shaft	SUS431 / SUS316
44	Coupling	SUS304 / SUS316
47	Strap	SUS304 / SUS316
52	Cable Guard	SUS304 / SUS316
86	Valve Seat	NBR
87	Neck Ring	SUS304+NBR / SUS316+NBR
88	Nut	SUS304 / SUS316
89	Bearing	NBR
90	Bearing	US304+NBR / SUS316+NBR
91	Screw	SUS304 / SUS316
92	Key	SUS304 / SUS316
93	O-ring	NBR
94	O-ring	NBR
95	Spring	SUS304 / SUS316
98	Spring Washer	SUS304 / SUS316

*AISI 316 stainless steel pumps are available on request.

General Data

Example: A-250

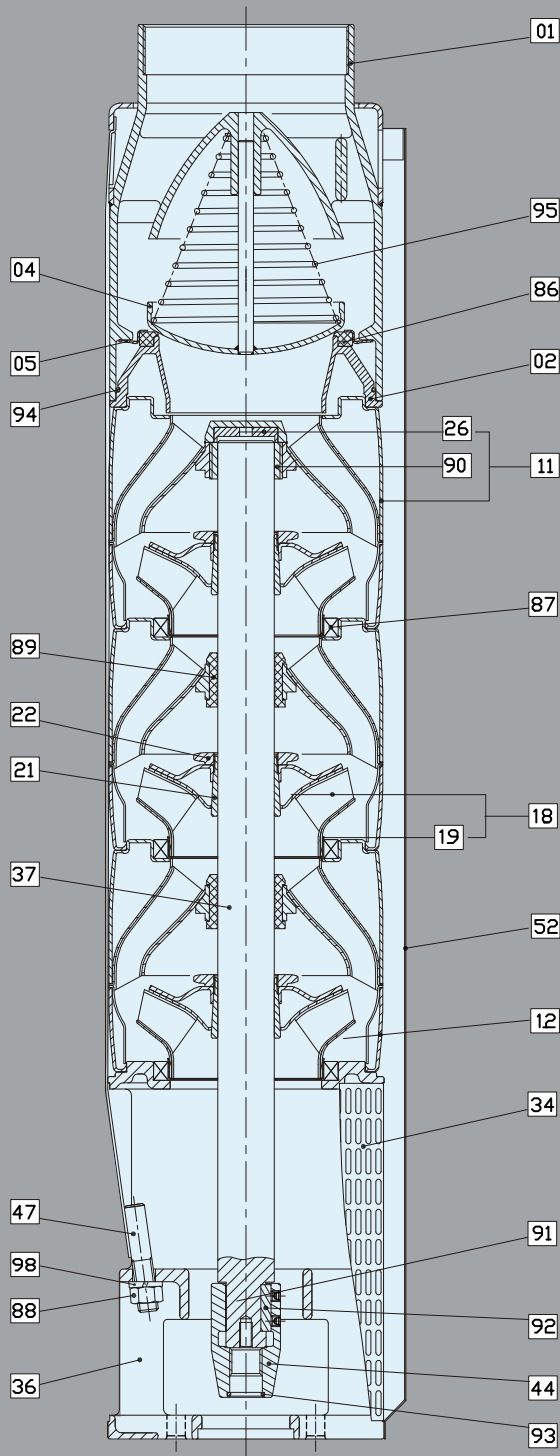

Material Specification-10" Pumps

Pos.	Components	Standard
01	Discharge	SUS304 / SUS316
02	Lower Valve Seat Retainer	SUS304 / SUS316
04	Valve Cup	SUS304 / SUS316
05	Upper Valve Seat Retainer	SUS304 / SUS316
11	Upper Diffuser	SUS304 / SUS316
+26	Spacing Washer For Stop Ring	Carbon Fiber+MoS2+PTFE
+90	Upper Bearing	SUS304+NBR / SUS316+NBR
12	Diffuser	SUS304 / SUS316
18	Impeller	SUS304 / SUS316
18	Impeller - A	SUS304 / SUS316
+19	Ring Of Impeller	SUS304 / SUS316
21	Split Cone	SUS304 / SUS316
22	Split Cone Nut	SUS304 / SUS316
34	Strainer - one lead	SUS304 / SUS316
34	Strainer - two leads	SUS304 / SUS316
36	Suction Interconnector - 6"	SUS304 / SUS316
36	Suction Interconnector - 8"	SUS304 / SUS316
37	Shaft	SUS431 / SUS316
44	Coupling - 6"	SUS304 / SUS316
44	Coupling - 8"	SUS304 / SUS316
47	Strap	SUS304 / SUS316
52	Cable Guard	SUS304 / SUS316
86	Valve Seat	NBR70
87	Neck Ring	PPS+NBR
88	Nut	SUS304 / SUS316
89	Bearing	NBR70
91	Screw - 6"	SUS304 / SUS316
91	Screw - 8"	SUS304 / SUS316
92	Key - 6"	SUS304 / SUS316
92	Key - 8"	SUS304 / SUS316
93	O-ring - 6"	NBR70
93	O-ring - 8"	NBR70
94	O-ring	NBR70
95	Spring	SUS304 / SUS316
98	Spring Washer	SUS304

*AISI 316 stainless steel pumps are available on request.

General Data

4" Stainless Steel Submersible Pumps

SPEED A 4" range of submersible pumps are made of corrosion and abrasion resistant stainless steel and have been developed in accordance with state of the art technology. The A 4" pumps are manufactured to the highest standards of highly efficient hydraulic impeller and diffuser design to reach high energy efficiency, dependable performance, rugged construction and long service life, even in difficult environments.

Applications

- ◆ Potable water supply
- ◆ Agricultural irrigation and livestock watering
- ◆ Municipal and industrial water supply
- ◆ Pressure boosting
- ◆ Mining applications
- ◆ Groundwater lowering
- ◆ Fountain

Pumped Liquids

- ◆ Clean, thin, non-aggressive and non-corrosive liquids without solid particles or fibers.

Operating Conditions

- ◆ Capacity (m³/h) min 0.3 max 18
- ◆ Total Head: Max. 625 m
- ◆ Max. ambient temperature (Liquid):30°C
- ◆ Sand content: Max. 50 g/m³
- ◆ Screen size of each hole:

5 x 1 mm (A-1~2)

Ø2.5 mm (A-3~5)

20 x 4 mm (A-8~14)

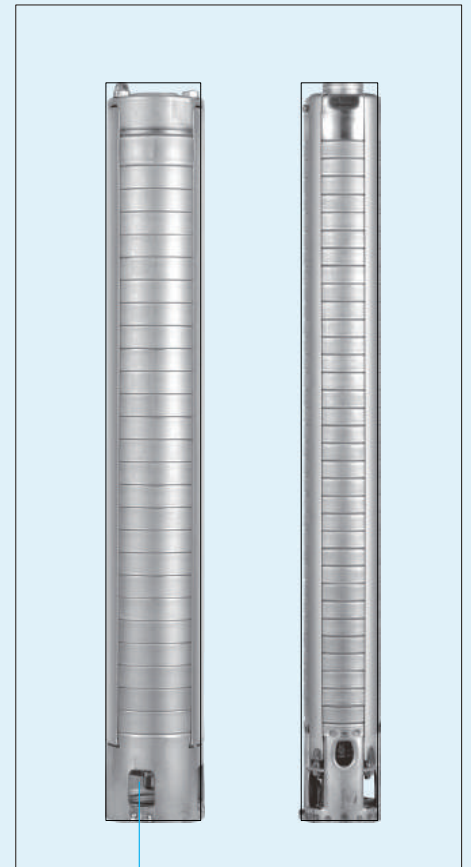

Features

- ◆ Stainless steel construction designed and built for years of trouble free operation
- ◆ Designed and built to operate in difficult conditions.
- ◆ All metal parts are made of 304 or 316 stainless steel, except for the shafts, which are made of 431, 304 or 316 stainless steel.
- ◆ Heavy duty stainless steel discharge head with built-in check valve for preventing back flow in connection with pump stoppage and the risk of destructive water hammer is reduced to a minimum.
- ◆ Smooth safety hook.
- ◆ NEMA standard of bracket mounting.
- ◆ High quality shaft bearings provide low friction and high wear resistance.
- ◆ The stop ring prevents damage to the pump during transport and in case of up-thrust in connection with start-up. The stop ring, which is designed as a thrust bearing, limits axial movements of the pump shaft.
- ◆ Stainless steel strainer to restrict the entry of sand and other extraneous material.

6" Stainless Steel Submersible Pumps

SPEED A 6" range of submersible pumps are made of corrosion and abrasion resistant stainless steel and have been developed in accordance with state of the art technology. The A 6" pumps are manufactured to the highest standards of highly efficient hydraulic impeller and diffuser design to reach high energy efficiency, dependable performance, rugged construction and long service life, even in difficult environments.

Applications

- ◆ Potable water supply
- ◆ Agricultural irrigation and livestock watering
- ◆ Municipal and industrial water supply
- ◆ Pressure boosting
- ◆ Mining applications
- ◆ Groundwater lowering
- ◆ Fountain

Pumped Liquids

- ◆ Clean, thin, non-aggressive and non-corrosive liquids without solid particles or fibers.

Operating Conditions

- ◆ Capacity (m³/h) min 3 max 78
- ◆ Total Head: Max. 648 m
- ◆ Max. ambient temperature (Liquid):30°C
- ◆ Sand content: Max. 50 g/m³
- ◆ Screen size of each hole: 20 x 4 mm



Features

- ◆ Stainless steel construction designed and built for years of trouble free operation
- ◆ Designed and built to operate in difficult conditions.
- ◆ All metal parts are made of 304 or 316 stainless steel, except for the shafts, which are made of 431 or 316 stainless steel.
- ◆ Heavy duty stainless steel discharge head with built-in check valve for preventing back flow in connection with pump stoppage and the risk of destructive water hammer is reduced to a minimum.
- ◆ NEMA standard of bracket mounting.
- ◆ High quality shaft bearings provide low friction and high wear resistance.
- ◆ The stop ring prevents damage to the pump during transport and in case of up-thrust in connection with start-up. The stop ring, which is designed as a thrust bearing, limits axial movements of the pump shaft.
- ◆ Stainless steel strainer to restrict the entry of sand and other extraneous material.

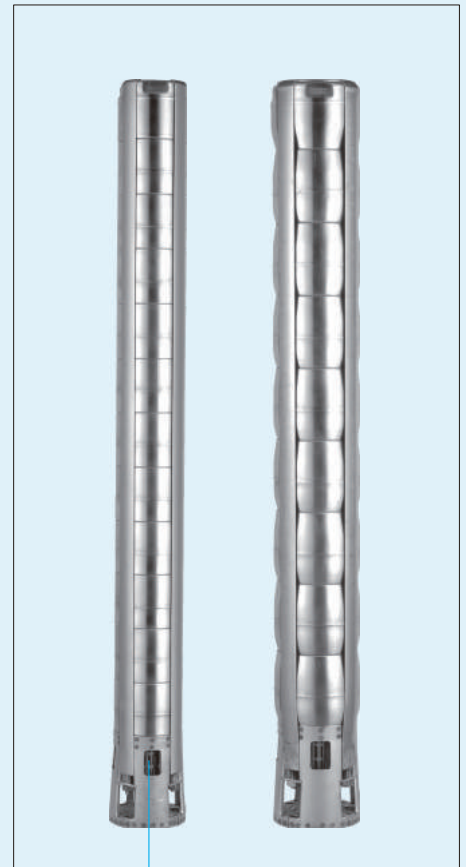

General Data

8" Stainless Steel Submersible Pumps

SPEED A 8" range of submersible pumps are made of corrosion and abrasion resistant stainless steel and have been developed in accordance with state of the art technology, which is also for heavy duty and high volume pumping application. The A 8" pumps are manufactured to the highest standards of highly efficient hydraulic impeller and diffuser design to reach high energy efficiency, dependable performance, rugged construction and long service life, even in difficult environments.

Applications

- ◆ Potable water supply
- ◆ Agricultural irrigation and livestock watering
- ◆ Municipal and industrial water supply
- ◆ Pressure boosting
- ◆ Mining applications
- ◆ Groundwater lowering
- ◆ Fountain

Pumped Liquids

- ◆ Clean, thin, non-aggressive and non-corrosive liquids without solid particles or fibers.

Operating Conditions

- ◆ Capacity (m³/h) min 12 max 120
- ◆ Total Head: Max. 441 m
- ◆ Max. ambient temperature (Liquid):30°C
- ◆ Sand content: Max. 50 g/m³

Screen size of each hole: 20 x 4 mm



Features

- ◆ Stainless steel construction designed and built for years of trouble free operation
- ◆ Designed and built to operate in difficult conditions.
- ◆ All metal parts are made of 304 or 316 stainless steel, except for the shafts, which are made of 431 or 316 stainless steel.
- ◆ Heavy duty stainless steel discharge head with built-in check valve for preventing back flow in connection with pump stoppage and the risk of destructive water hammer is reduced to a minimum.
- ◆ NEMA standard of bracket mounting.
- ◆ High quality shaft bearings provide low friction and high wear resistance.
- ◆ The stop ring prevents damage to the pump during transport and in case of up-thrust in connection with start-up. The stop ring, which is designed as a thrust bearing, limits axial movements of the pump shaft.
- ◆ Stainless steel strainer to restrict the entry of sand and other extraneous material.

10" Stainless Steel Submersible Pumps

SPEED A 10" range of submersible pumps are made of corrosion and abrasion resistant stainless steel and have been developed in accordance with state of the art technology, which is also for heavy duty and high volume pumping application. The A 10" pumps are manufactured to the highest standards of highly efficient hydraulic impeller and diffuser design to reach high energy efficiency, dependable performance, rugged construction and long service life, even in difficult environments.

Applications

- ◆ Potable water supply
- ◆ Agricultural irrigation and livestock watering
- ◆ Municipal and industrial water supply
- ◆ Pressure boosting
- ◆ Mining applications
- ◆ Groundwater lowering
- ◆ Fountain

Pumped Liquids

- ◆ Clean, thin, non-aggressive and non-corrosive liquids without solid particles or fibers.

Operating Conditions

- ◆ Capacity (m³/h) min16 max 280
- ◆ Total Head: Max. 502m
- ◆ Max. ambient temperature (Liquid):30°C
- ◆ Sand content: Max. 50 g/m³

Screen size of each hole: 20 x 4 mm

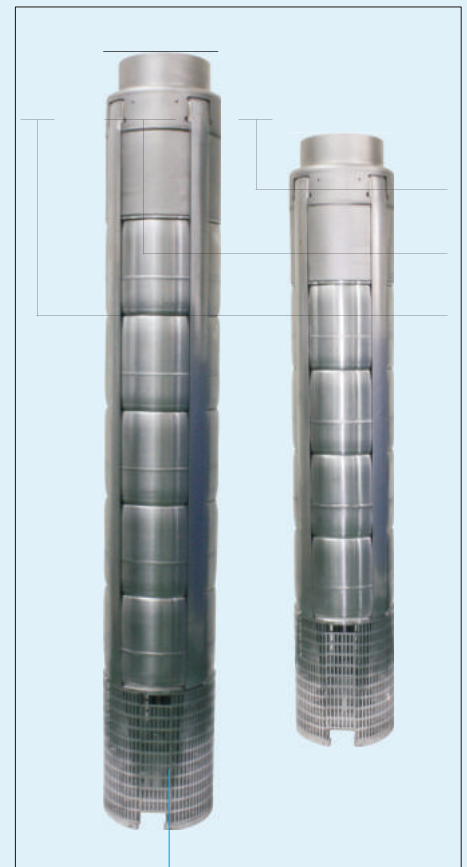

Features

- ◆ Stainless steel construction designed and built for years of trouble free operation
- ◆ Designed and built to operate in difficult conditions.
- ◆ All metal parts are made of 304 or 316 stainless steel, except for the shafts, which are made of 431 or 316 stainless steel.
- ◆ Heavy duty stainless steel discharge head with built-in check valve for preventing back flow in connection with pump stoppage and the risk of destructive water hammer is reduced to a minimum.
- ◆ High quality shaft bearings provide low friction and high wear resistance.
- ◆ The stop ring prevents damage to the pump during transport and in case of up-thrust in connection with start-up. The stop ring, which is designed as a thrust bearing, limits axial movements of the pump shaft.
- ◆ Stainless steel strainer to restrict the entry of sand and other extraneous material.

SPEED A Series

A 4"

A-1 Performance Curves

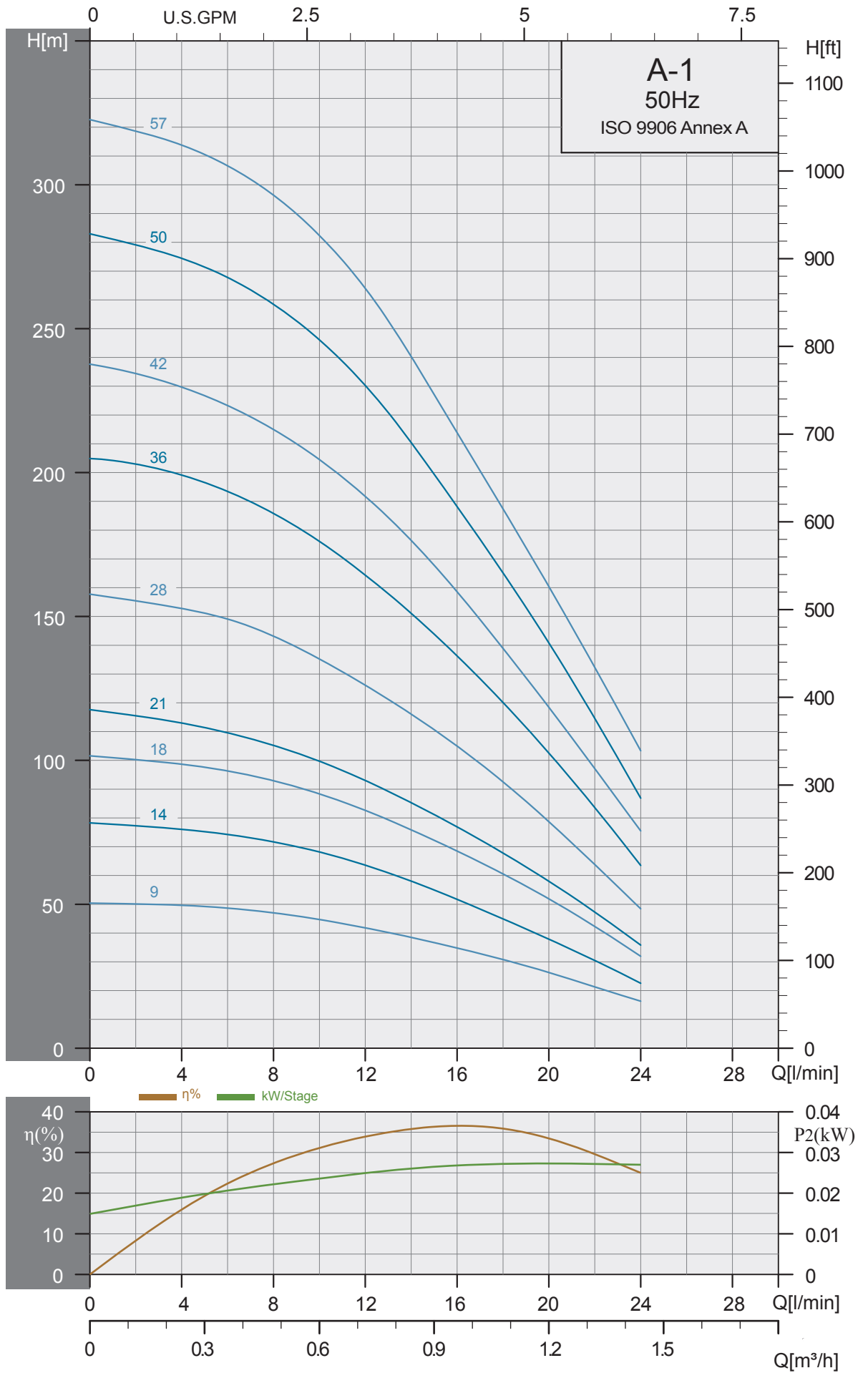

Selection Chart

50Hz

Pump Type	Motor		Q capacity 2850 rpm						
	P2		l/min m ³ /h	0	5	10	15	20	25
	KW	HP		0	0.3	0.6	0.9	1.2	1.5
A 1-09	0.37	0.5	HEAD IN METERS	50	47	45	36	26	14
A 1-14	0.37	0.5		78	75	68	55	38	21
A 1-18	0.55	0.75		102	97	88	72	52	27
A 1-18	0.55	0.75		118	111	100	81	58	30
A 1-28	0.75	1		158	151	138	111	79	42
A 1-36	1.1	1.5		205	196	175	144	103	54
A 1-42	1.1	1.5		238	227	203	168	118	67
A 1-50	1.5	2		283	271	246	199	140	72.5
A 1-57	2	3		322	310	282	227	160	88.5

*Higher pressure , longer stages pumps up to 57 stages are available on request.

Dimensions and weights

Pump Type	Motor Dia.	Dimensions (mm)		Net Weight (Kg) Pump
		A	C	
A 1-09	4"	356	98	2.9
A 1-14	4"	461	98	3.7
A 1-18	4"	545	98	4.4
A 1-18	4"	608	98	5.0
A 1-28	4"	755	98	6.2
A 1-36	4"	946	98	9.9
A 1-42	4"	1072	98	11.3
A 1-50	4"	1240	98	13.2
A 1-57	4"	1387	98	14.8

C= Maximum diameter of pump inclusive of cable guard and motor.

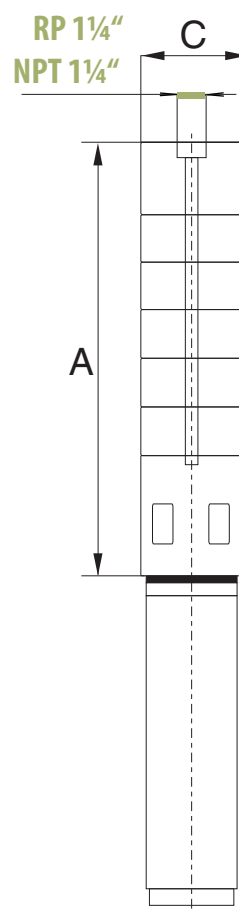

SPEED A Series

A 4"

A-2

Performance Curves

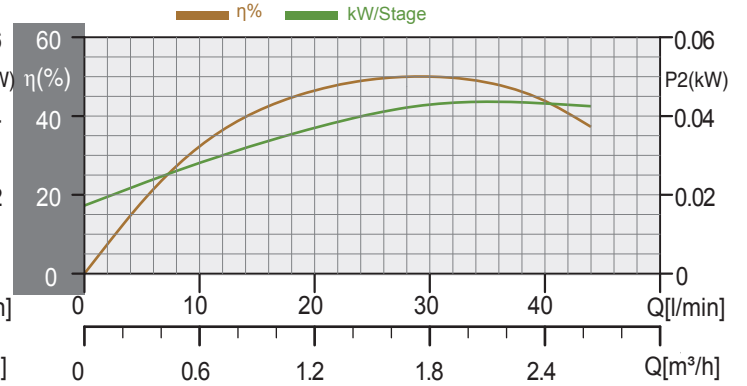
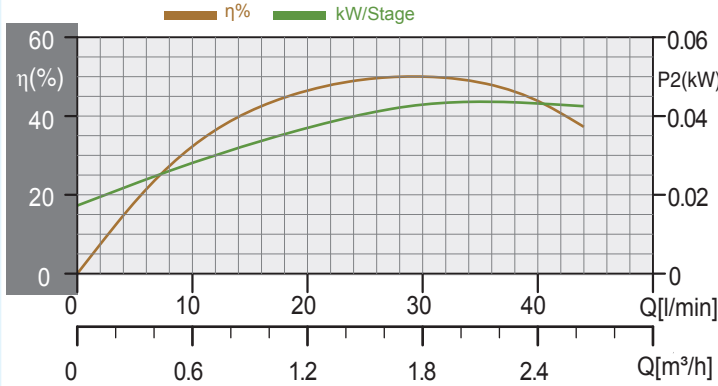
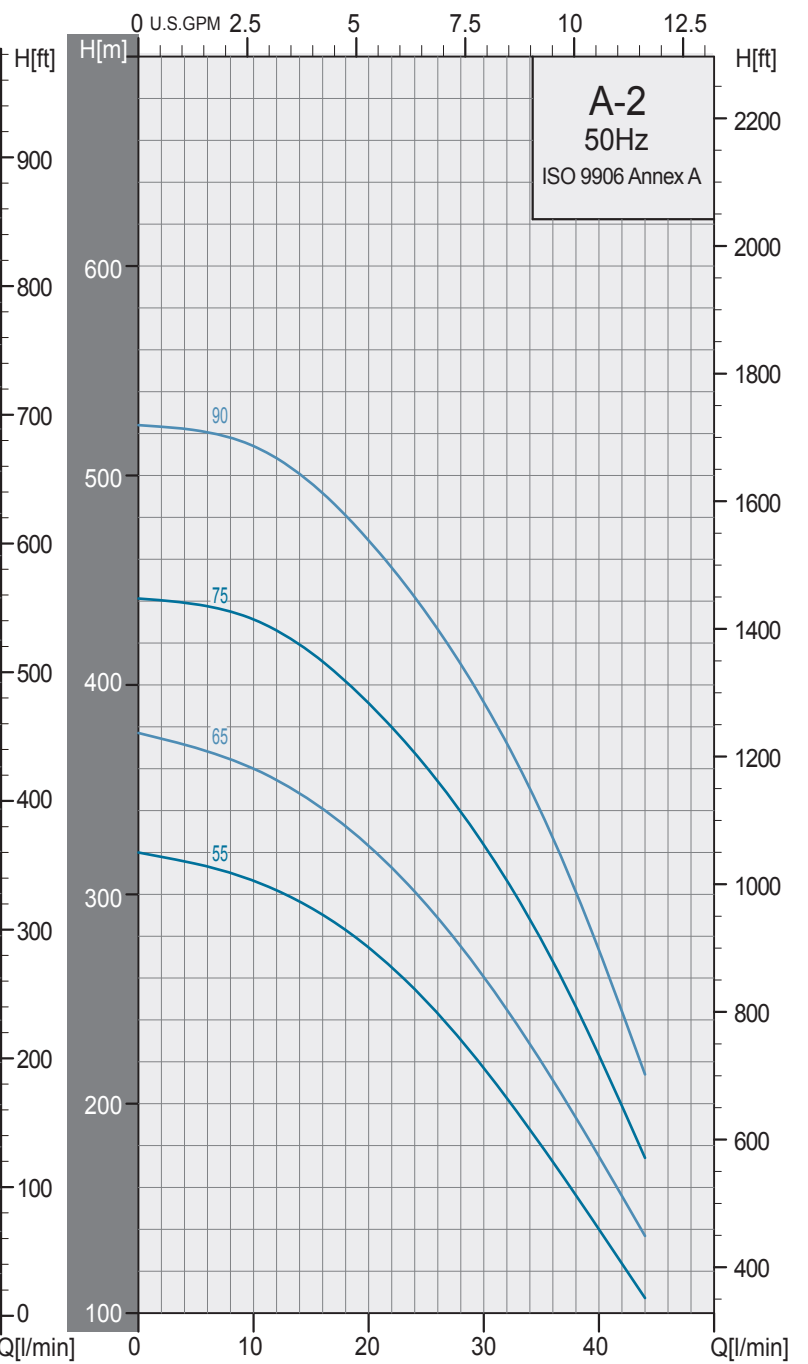
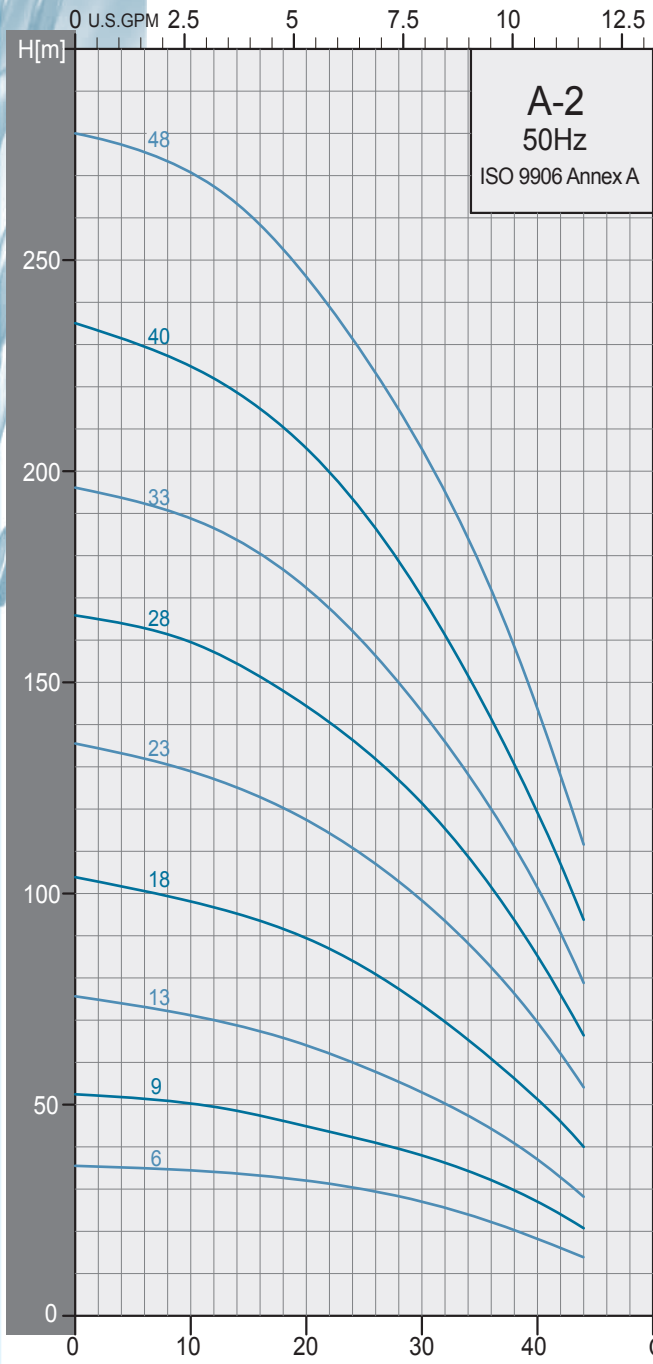

Selection Chart

50Hz

Pump Type	Motor		Q capacity 2850 rpm							
	P2		l/min m³/h	0	15	20	25	30	35	40
	KW	HP		0	0.9	1.2	1.5	1.8	2.1	2.4
A 2-06	0.37	0.5	HEAD IN METERS	36	34	32	30	27	23	18
A 2-09	0.37	0.5		52	48	45	42	38	33	27
A 2-13	0.55	0.75		76	68	64	59	53	46	37
A 2-18	0.75	1		104	94	89	82	74	63	51
A 2-23	1.1	1.5		136	124	117	109	98	85	69
A 2-28	1.5	2		166	153	144	134	121	105	85
A 2-33	1.5	2		196	182	172	159	143	124	101
A 2-40	2.2	3		235	217	205	190	170	147	119
A 2-48	2.2	3		280	261	246	227	205	178	144
A 2-55	3	4		320	293	275	249	217	180	140
A 2-65	3	4		377	345	323	294	260	220	175
▶ A 2-75	4	5.5		441	415	391	360	324	278	223
▶ A 2-90	4	5.5		524	496	469	434	392	339	273

*Higher pressure , longer stages pumps up to 90 stages are available on request.

▶ With Sleeve .

Dimensions and weights

Pump Type	Motor Dia.	Dimensions (mm)		Net Weight (Kg) Pump
		A	C	
A 2-06	4"	293	98	2.3
A 2-09	4"	356	98	3.0
A 2-13	4"	440	98	3.8
A 2-18	4"	545	98	4.7
A 2-23	4"	650	98	5.7
A 2-28	4"	755	98	6.6
A 2-33	4"	883	98	9.7
A 2-40	4"	1030	98	11.5
A 2-48	4"	1198	98	13.5
A 2-55	4"	1345	98	15.3
A 2-65	4"	1555	98	17.8
▶ A 2-75	4"	2123	133	40.1
▶ A 2-90	4"	2438	133	45.6

C=Max. diameter of pump inclusive of cable guard and motor.

A 10-75 and A 10-90 are mounted in sleeve for R 1 1/4 connection

▶ With Sleeve .

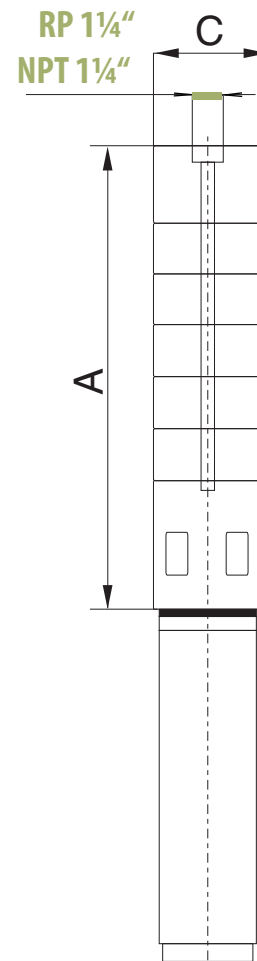

SPEED A Series

A

4"

Performance Curves

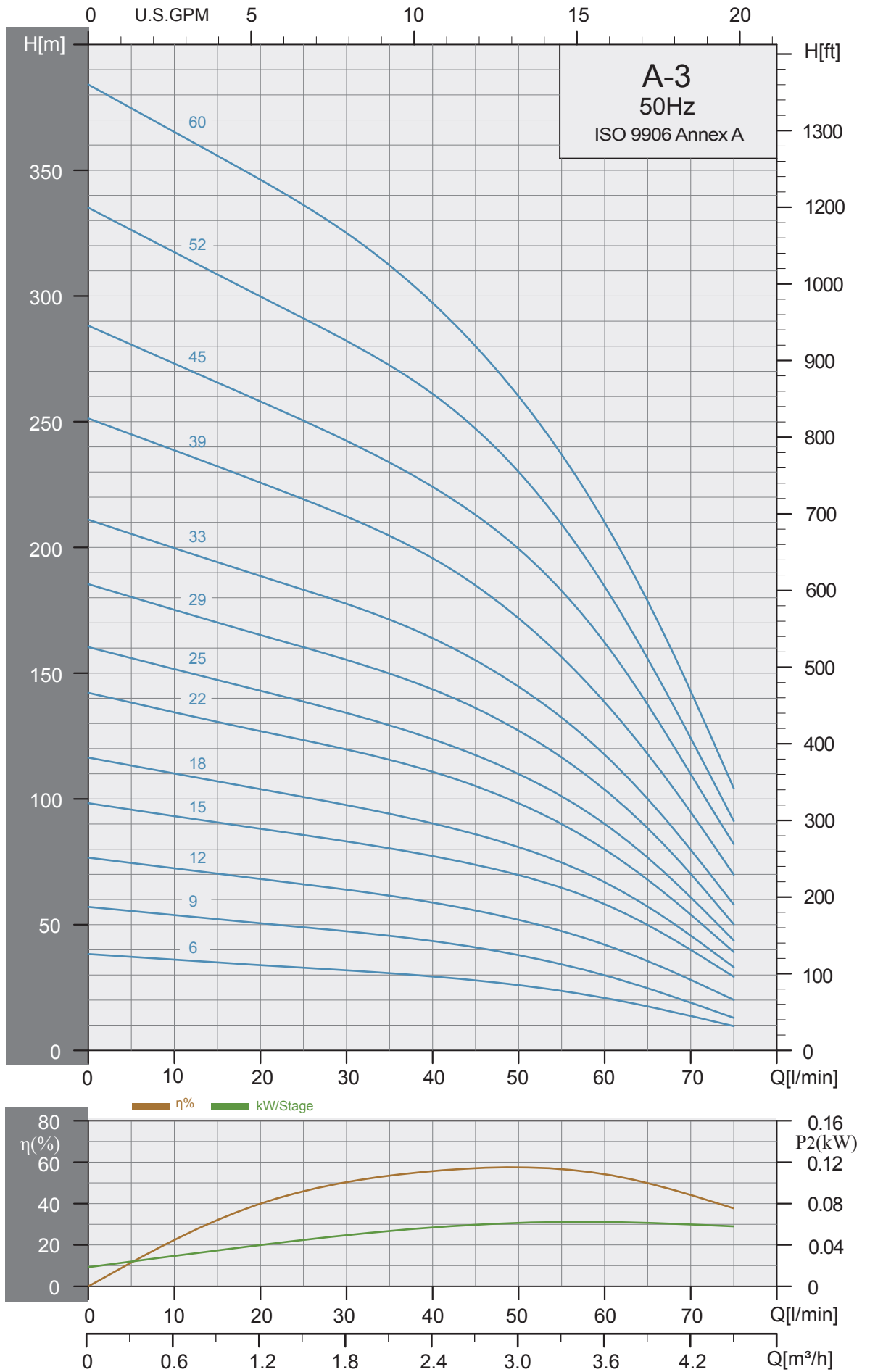

Selection Chart

50Hz

Pump Type	Motor		Q capacity 2850 rpm									
	P2		l/min m³/h	0	25	30	35	40	45	50	60	70
	KW	HP		0	1.5	1.8	2.1	2.4	2.7	3.0	3.6	4.2
A 3-06	0.37	0.5	HEAD IN METERS	38	33	32	31	30	28	26	21	14
A 3-09	0.55	0.75		57	49	47	46	43	41	38	30	19
A 3-12	0.75	1		77	66	64	62	58	56	52	42	28
A 3-15	1.1	1.5		97	85	83	80	77	74	69	57	40
A 3-18	1.1	1.5		116	101	97	94	90	85	80	67	45
A 3-22	1.5	2		142	123	120	115	110	105	98	80	54
A 3-25	1.5	2		160	139	134	129	123	117	110	90	61
A 3-29	2.2	3		185	160	155	150	143	136	127	103	70
A 3-33	2.2	3		211	183	177	171	164	155	145	118	80
A 3-39	3	4		251	219	212	205	196	185	172	138	95
A 3-45	3	4		288	250	242	234	224	213	199	162	110
A 3-52	4	5.5		334	291	282	272	261	247	230	184	124
A 3-60	4	5.5		384	336	325	312	297	280	260	210	143

*Higher pressure , longer stages pumps up to 60 stages are available on request.

Dimensions and weights

Pump Type	Motor Dia.	Dimensions (mm)		Net Weight (Kg) Pump
		A	C	
A 3-06	4"	293	98	2.4
A 3-09	4"	356	98	3.0
A 3-12	4"	419	98	3.6
A 3-15	4"	482	98	4.2
A 3-18	4"	545	98	4.7
A 3-22	4"	629	98	5.5
A 3-25	4"	692	98	6.1
A 3-29	4"	776	98	6.8
A 3-33	4"	883	98	9.7
A 3-39	4"	1009	98	11.2
A 3-45	4"	1135	98	12.7
A 3-52	4"	1282	98	14.5
A 3-60	4"	1450	98	16.6

C= Maximum diameter of pump inclusive of cable guard and moter.

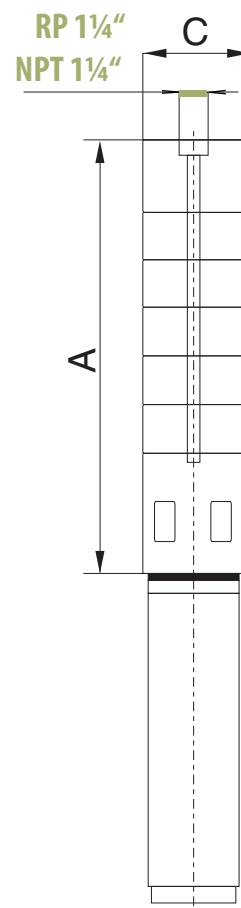

SPEED A Series

A 4"

A-5 Performance Curves

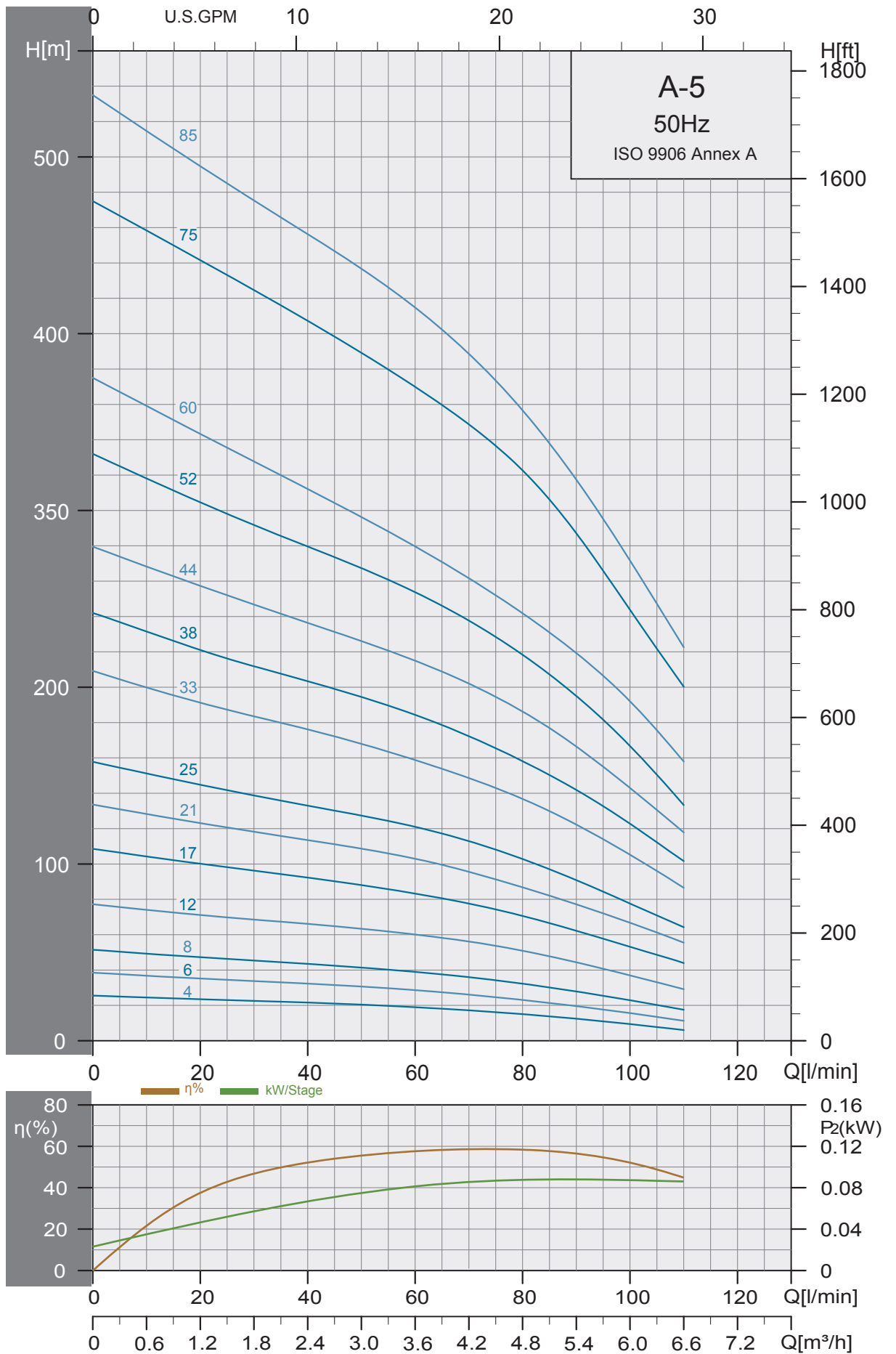

Selection Chart

50Hz

Pump Type	Motor		Q capacity 2850 rpm											
	P2		l/min m³/h	0	30	35	40	45	50	60	70	80	90	100
	KW	HP		0	1.8	2.1	2.4	2.7	3.0	3.6	4.2	4.8	5.4	6.0
A 5-04	0.37	0.5	HEAD IN METERS	25	23	22	21	20.5	20	19	17	15	12	10
A 5-06	0.55	0.75		38	34	33	32	31	30	28	26	23	20	16
A 5-08	0.75	1		51	45	44	43	42	41	39	36	32	28	23
A 5-12	1.1	1.5		77	68	67	66	64	63	60	56	51	44	37
A 5-17	1.5	2		108	96	94	92	90	88	83	77	70	62	53
A 5-21	2.2	3		134	118	115	113	111	108	103	96	87	77	67
A 5-25	2.2	3		157	138	136	133	130	127	121	113	103	90	78
A 5-33	3	4		209	184	180	176	172	168	159	149	137	122	105
A 5-38	4	5.5		242	212	208	203	199	194	184	172	158	142	123
A 5-44	4	5.5		279	247	242	237	231	226	215	202	187	166	143
A 5-52	5.5	7.5		332	291	285	279	273	267	253	237	218	195	166
A 5-60	5.5	7.5		375	327	320	312	304	296	279	261	242	219	192
A 5-75	7.5	10		475	424	416	407	398	389	370	348	322	287	243
A 5-85	7.5	10		535	475	466	456	446	436	414	388	356	317	271

*Higher pressure , longer stages pumps up to 85 stages are available on request.

▶ With Sleeve .

Dimensions and weights

Pump Type	Motor Dia.	Dimensions (mm)		Net Weight (Kg) Pump
		A	C	
A 5-04	4"	251	98	2.0
A 5-06	4"	293	98	2.4
A 5-08	4"	335	98	2.8
A 5-12	4"	419	98	3.6
A 5-17	4"	524	98	4.5
A 5-21	4"	608	98	5.3
A 5-25	4"	692	98	6.0
A 5-33	4"	868	98	9.6
A 5-38	4"	973	98	10.9
A 5-44	4"	1099	98	12.4
A 5-52	4"	1267	98	14.4
	6"	1341	138	16.5
A 5-60	4"	1435	98	16.4
	6"	1509	138	18.5
A 5-75	6"	2171	140	41.5
A 5-85	6"	2335	140	45.5

C=Maximum diameter of pump inclusive of cable guard and motor.

A 5-75 and A 5-85 are mounted in sleeve for R 1 1/2 connection

▶ With Sleeve .

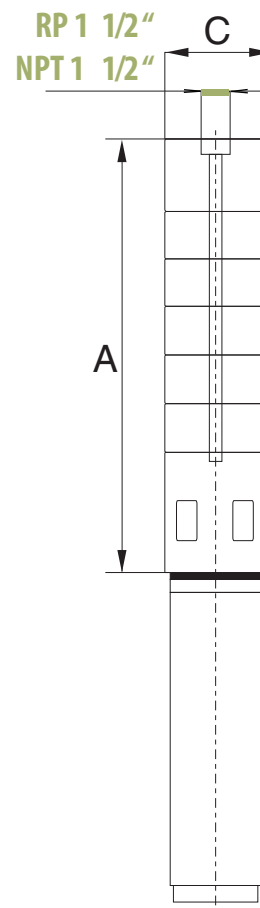

SPEED A Series

A 4"

A-8

Performance Curves

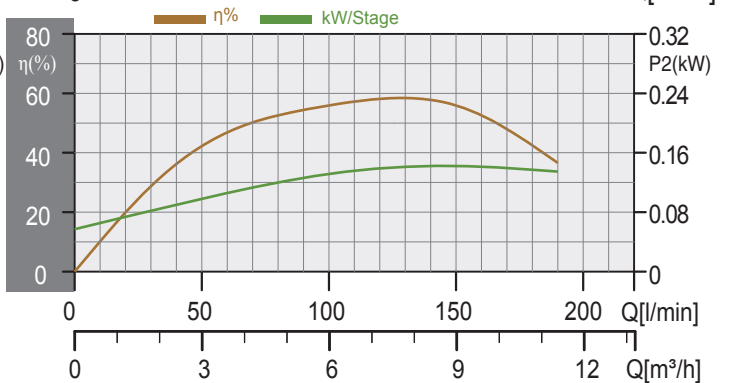
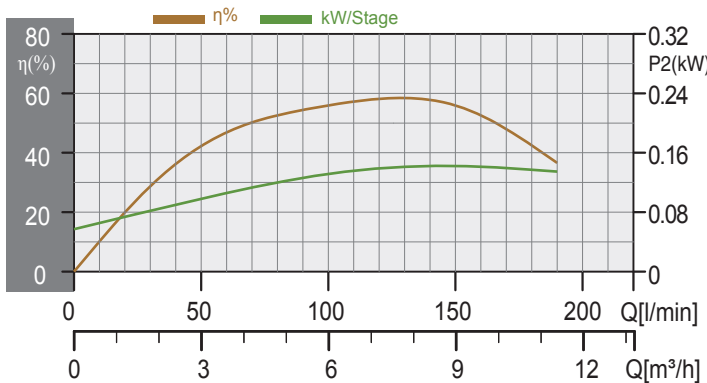
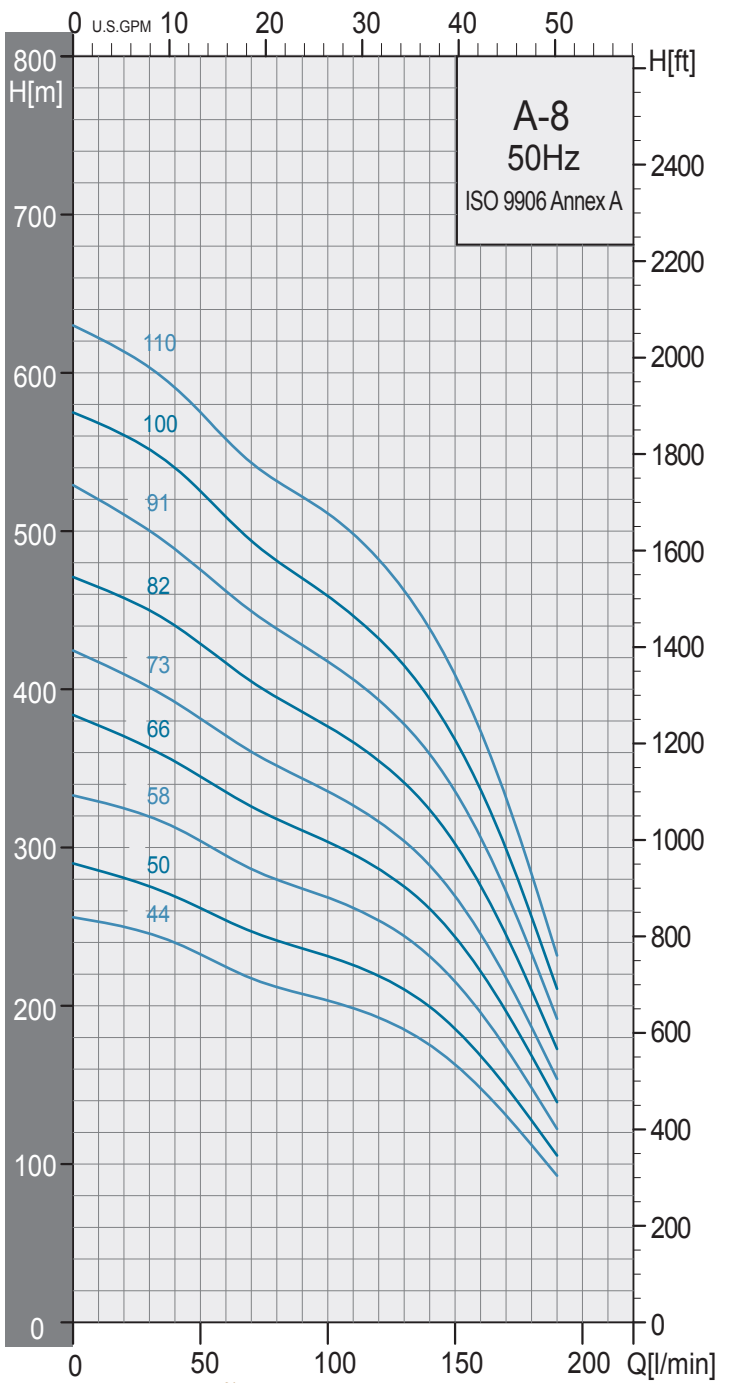
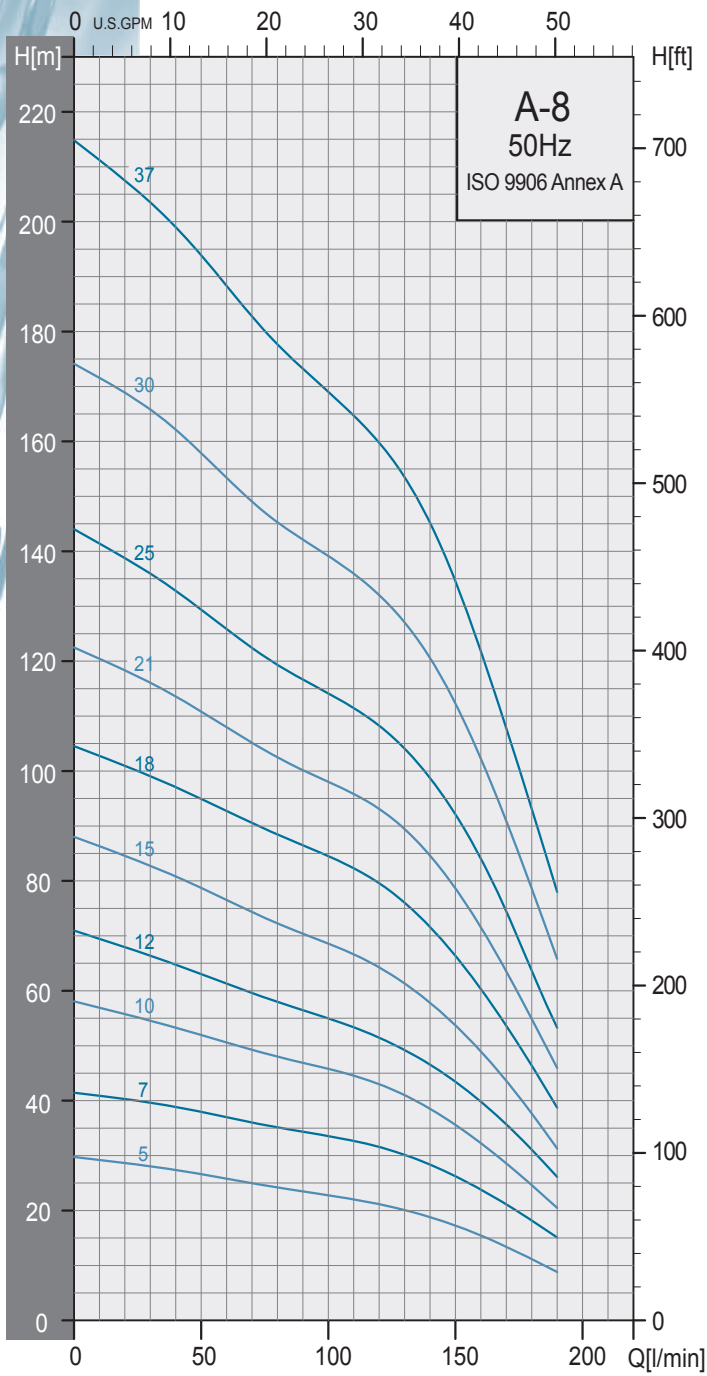

Selection Chart

50Hz

Pump Type	Motor		Q capacity 2850 rpm													
	P2		l/min m³/h	0	40	45	50	60	70	80	90	100	120	140	160	180
	KW	HP		0	2.4	2.7	3.0	3.6	4.2	4.8	5.4	6.0	7.2	8.4	9.6	10.8
A 8-05	0.75	1	HEAD IN METERS	30	28	27	26	26	25	24	23	22	21	19	15	11
A 8-07	1.1	1.5		41	39	38	38	37	36	35	34	33	32	28	24	18
A 8-10	1.5	2		58	54	53	52	51	49	48	47	46	43	38	32	25
A 8-12	2.2	3		71	65	64	63	61	60	58	56	55	52	47	40	31
A 8-15	2.2	3		88	80	79	78	76	74	72	70	68	64	57	49	38
A 8-18	3	4		104	98	96	95	93	90	88	86	84	79	72	60	46
A 8-21	4	5.5		122	114	112	111	107	105	102	100	98	93	85	72	55
A 8-25	4	5.5		144	133	131	129	126	122	119	116	114	108	98	84	64
A 8-30	5.5	7.5		174	163	160	157	154	149	145	142	139	132	120	102	79
A 8-37	5.5	7.5		215	199	196	194	188	183	177	173	169	160	145	122	93
A 8-44	7.5	10		256	240	236	232	224	217	212	207	203	192	175	148	112
A 8-50	7.5	10		290	269	266	261	254	247	241	236	231	219	199	168	127
A 8-58	11	15		333	312	309	304	295	286	280	274	268	254	231	195	148
A 8-66	11	15		383	354	350	345	335	326	318	311	303	286	261	222	168
A 8-73	11	15		424	392	387	381	370	360	351	343	335	316	289	245	186
A 8-82	15	20		471	440	429	429	416	405	395	385	376	355	324	276	210
A 8-91	15	20		529	488	482	475	462	449	438	428	417	393	359	306	233
A 8-100	18.5	25	575	540	533	525	509	493	481	470	459	432	394	336	256	
A 8-110	18.5	25	630	590	583	575	558	543	531	521	511	482	438	373	283	

*Higher pressure , longer stages pumps up to 110 stages are available on request.

▶ With Sleeve .

Dimensions and weights

Pump Type	Motor Dia.	Dimensions (mm)		Net Weight (Kg) Pump
		A	C	
A 8-05	4"	412	98	4.3
A 8-07	4"	496	98	5.3
A 8-10	4"	622	98	6.8
A 8-12	4"	706	98	7.8
A 8-15	4"	832	98	9.3
A 8-18	4"	958	98	10.8
A 8-21	4"	1084	98	12.3
A 8-25	4"	1252	98	14.3
A 8-30	4"	1462	98	16.8
A 8-37	4"	1753	98	20.3
A 8-44	4"	2047	98	23.3
	6"	2113	138	25.5
A 8-50	4"	2299	98	26.4
	6"	2365	138	28.5
▶ A 8-58	6"	3005	140	58.2
▶ A 8-66	6"	3341	140	64.6
▶ A 8-73	6"	3635	140	70.4
▶ A 8-82	6"	4013	140	77.7
▶ A 8-91	6"	4391	140	85.1
▶ A 8-100	6"	4769	140	92.4
▶ A 8-110	6"	5189	140	100.6

C=Maximum diameter of pump inclusive of cable guard and motor.

A 8-58 to A 8-110 are mounted in sleeve for R 2 connection

▶ With Sleeve .

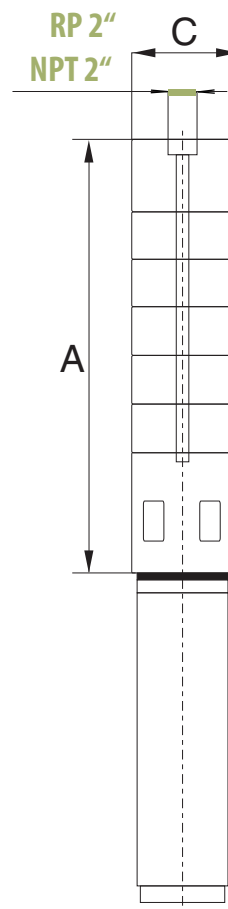

SPEED A Series

A 4"

A-14 Performance Curves

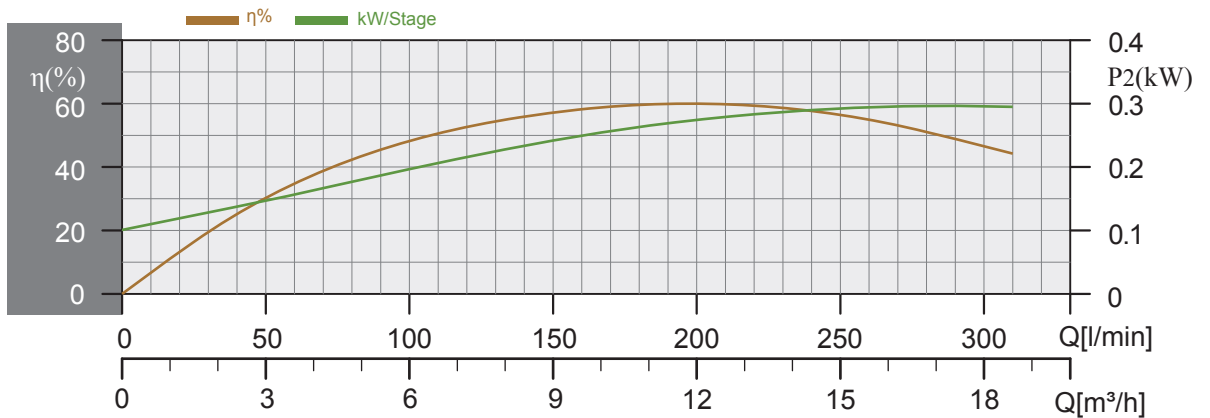
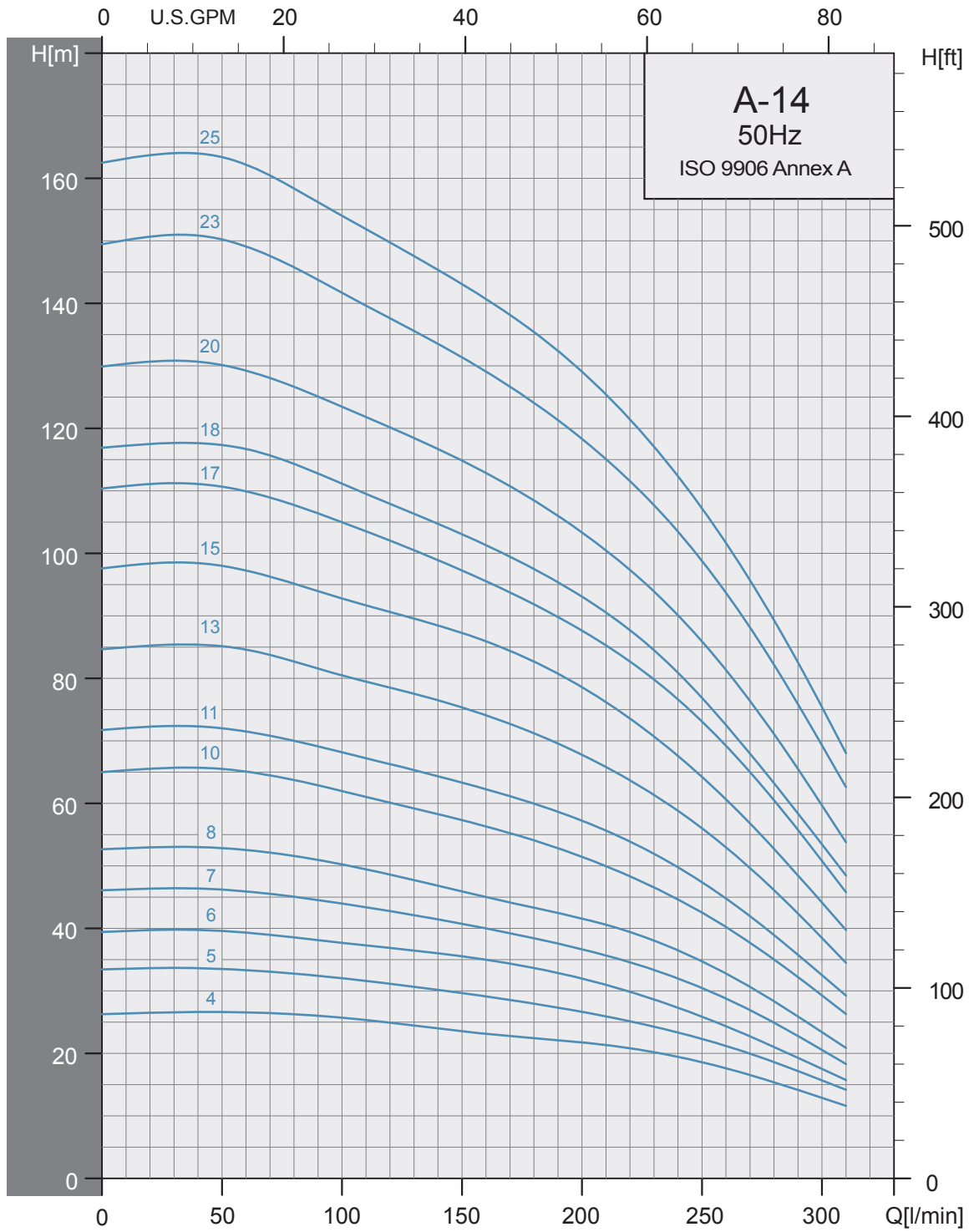

Selection Chart

50Hz

Pump Type	Motor		Q capacity 2850 rpm									
	P2		l/min m³/h	0	100	120	140	160	180	200	250	300
	KW	HP		0	6.0	7.2	8.4	9.6	10.8	12	15	18
A 14-04	1.1	1.5	HEAD IN METERS	26	25.5	25	24	23	22.5	21.5	18.5	13
A 14-05	1.5	2		33	32	31	30	29	28	26	22	16
A 14-06	2.2	3		39.5	37.5	37	36	35	33.5	32	26	17.5
A 14-07	2.2	3		46	44	43	42	40	38	36	30	20
A 14-08	3	4		52.5	50	48.5	46.5	45	43	41.5	35	23.5
A 14-10	3	4		65	62	60	58	56	54	51	43	29
A 14-11	4	5.5		71.5	68	66	64	62	60	57	47	32.5
A 14-13	4	5.5		84	80	78	77	74	71	67	56	38
A 14-15	5.5	7.5		97.5	92.5	90.5	88.5	86	82.5	78.5	64	44
A 14-17	5.5	7.5		110	105	102	99	95.5	92	87.5	73	51
A 14-18	5.5	7.5		117	111	108	104	102	97	93	77	54
A 14-20	7.5	10		130	123	120	116.5	113	108.5	103	86	59
A 14-23	7.5	10		149.5	141.5	137.5	133.5	129	124	118	99	69
A 14-25	7.5	10		163	154	149	145	141	135	129	107	75

Dimensions and weights

Pump Type	Motor Dia.	Dimensions (mm)		Net Weight (Kg) Pump
		A	C	
A 14-04	4"	440	98	4.4
A 14-05	4"	505	98	5.0
A 14-06	4"	570	98	5.7
A 14-07	4"	635	98	6.3
A 14-08	4"	700	98	7.0
A 14-10	4"	830	98	8.2
A 14-11	4"	895	98	8.9
A 14-13	4"	1025	98	10.2
A 14-15	4"	1155	98	11.5
A 14-17	4"	1285	98	12.8
A 14-18	4"	1350	98	13.4
A 14-20	4"	1480	98	14.7
A 14-23	4"	1675	98	16.6
A 14-25	4"	1805	98	17.8

C=Maximum diameter of pump inclusive of cable guard and moter.

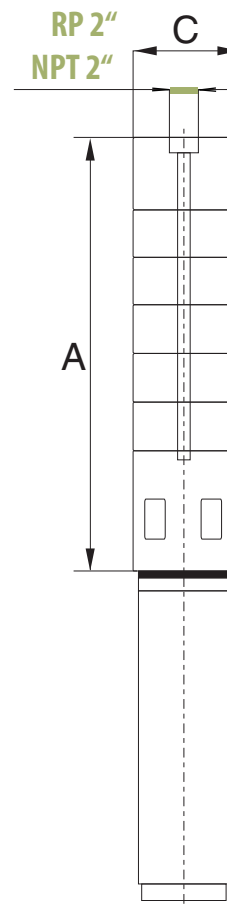

SPEED A Series

A 6"

A-22

Performance Curves

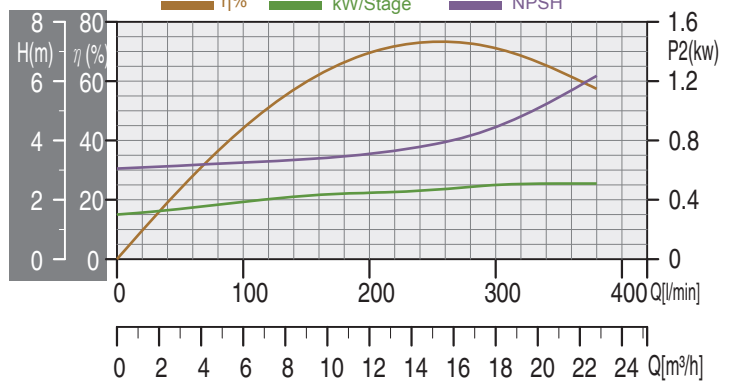
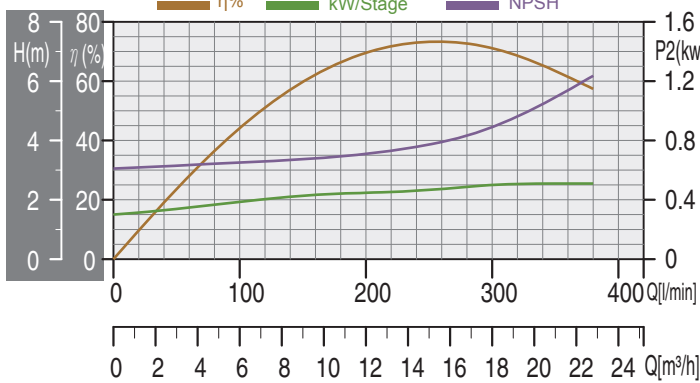
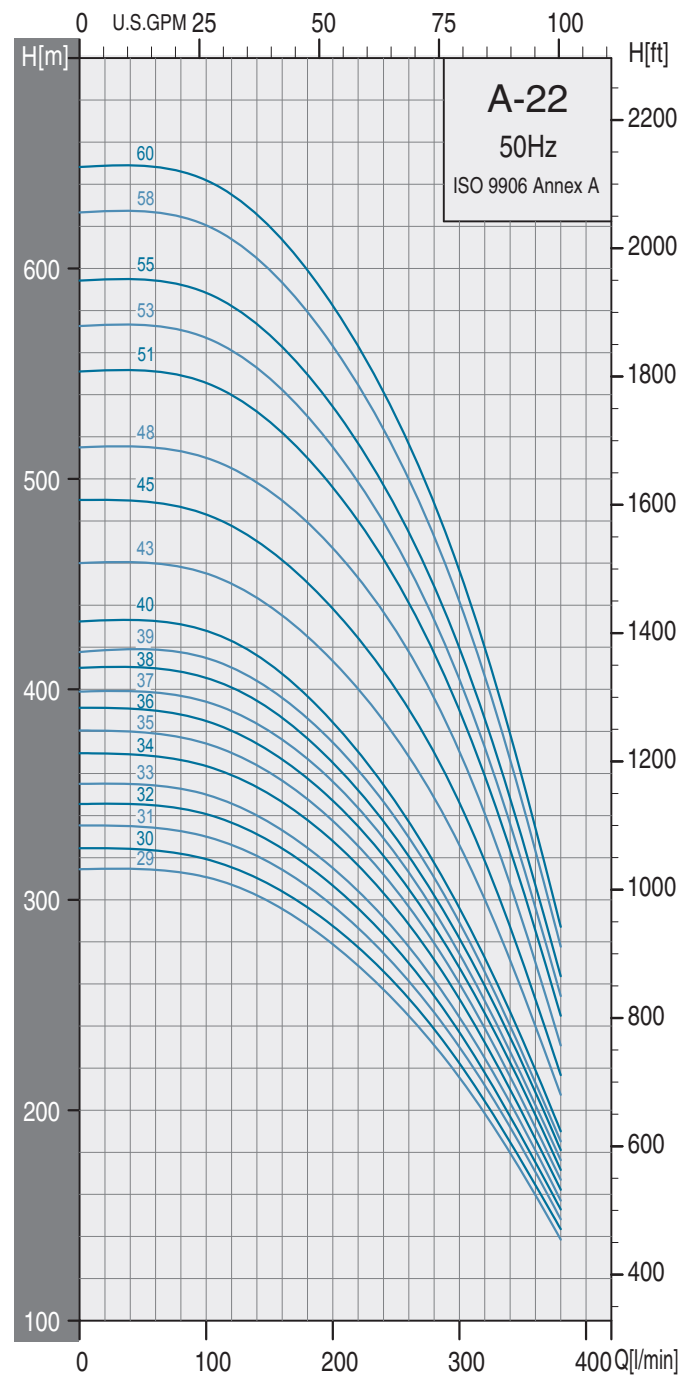
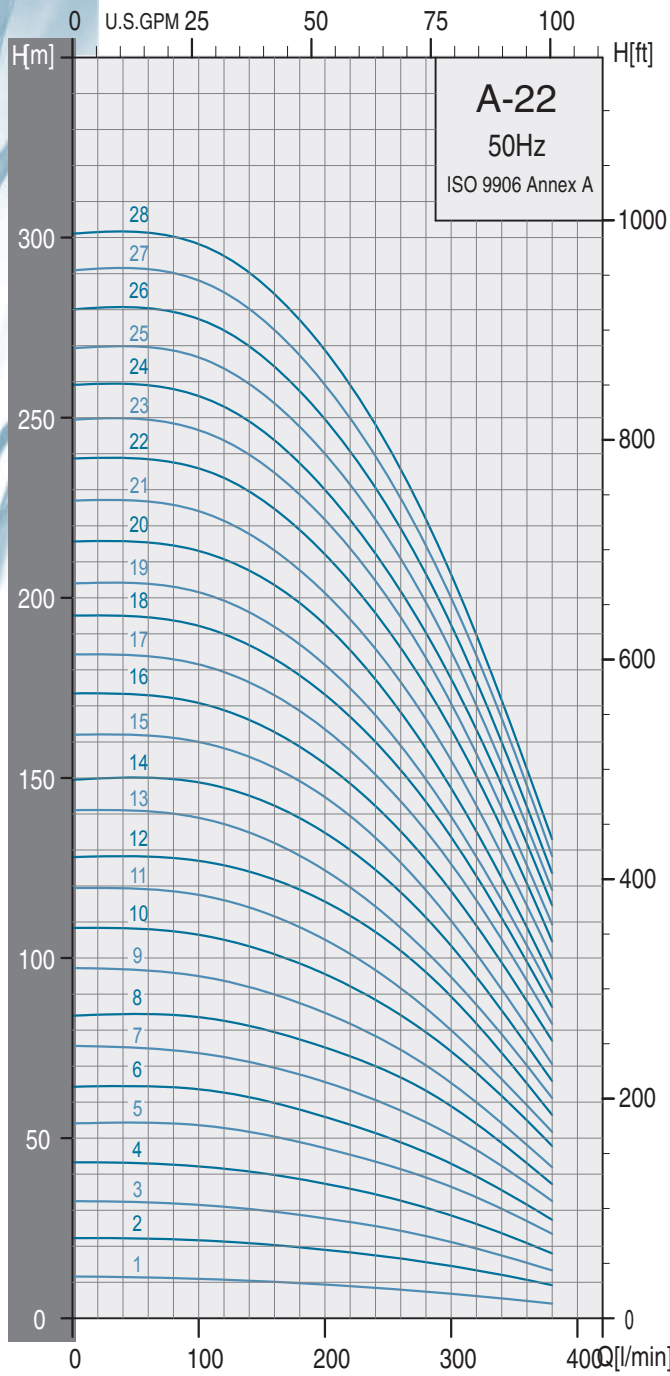

Selection Chart

50Hz

Dimensions and weights

Pump Type	Motor		m³/h l/min	Q capacity 2850 rpm							
	P2			3	6	9	12	15	18	21	23
	KW	HP		50	100	150	200	250	300	350	383
A 22-1	0.55	0.75	12	11	11	10	8	7	6	4	
A 22-2	1.1	1.5	22	22	20	19	18	14	12	9	
A 22-3	2.2	3	32	32	30	28	25	21	17	13	
A 22-4	2.2	3	43	42	40	38	33	29	23	18	
A 22-5	3	4	53	52	51	48	43	37	29	22	
A 22-6	3.7	5	64	63	60	56	50	43	34	27	
A 22-7	4	5.5	75	74	70	66	59	51	40	32	
A 22-8	5.5	7.5	85	84	80	75	68	59	46	37	
A 22-9	5.5	7.5	97	95	91	85	77	65	51	42	
A 22-10	5.5	7.5	108	107	102	95	86	74	58	48	
A 22-11	7.5	10	119	118	113	105	94	80	63	52	
A 22-12	7.5	10	128	127	123	116	105	89	69	57	
A 22-13	7.5	10	141	139	133	124	112	95	75	60	
A 22-14	9.3	12.5	150	149	144	135	122	103	81	66	
A 22-15	9.3	12.5	162	160	155	145	130	110	86	71	
A 22-16	9.3	12.5	173	171	165	154	139	119	93	77	
A 22-17	9.3	12.5	184	182	175	163	147	126	100	80	
A 22-18	9.3	12.5	195	192	185	173	156	134	105	86	
A 22-19	11	15	204	202	194	181	163	139	110	91	
A 22-20	11	15	216	213	206	192	173	147	116	95	
A 22-21	11	15	227	224	216	201	182	155	122	100	
A 22-22	13	17.5	239	237	228	212	190	163	129	105	
A 22-23	13	17.5	250	247	237	222	200	171	134	109	
A 22-24	13	17.5	260	257	247	230	208	178	140	115	
A 22-25	15	20	270	261	257	240	217	185	145	119	
A 22-26	15	20	281	278	267	250	225	192	151	124	
A 22-27	15	20	291	288	277	259	234	200	158	128	
A 22-28	18.5	25	302	298	288	269	242	207	162	133	
A 22-29	18.5	25	314	311	300	279	250	215	170	138	
A 22-30	18.5	25	324	319	307	288	260	222	175	144	
A 22-31	18.5	25	335	330	318	298	269	230	181	148	
A 22-32	18.5	25	345	341	328	307	277	237	187	153	
A 22-33	18.5	25	355	350	337	315	285	243	191	157	
A 22-34	18.5	25	369	364	350	328	296	253	199	162	
A 22-35	22	30	379	374	361	338	305	260	204	167	
A 22-36	22	30	390	385	371	348	313	268	210	170	
A 22-37	22	30	399	394	380	356	322	274	203	176	
A 22-38	22	30	410	405	390	365	330	281	222	180	
A 22-39	22	30	419	415	400	375	364	289	227	185	
A 22-40	22	30	433	428	412	384	346	296	235	190	
A 22-43	26	35	460	455	440	414	377	326	257	207	
A 22-45	26	35	489	483	466	438	400	346	271	217	
A 22-48	26	35	515	510	494	467	428	371	290	231	
A 22-51	30	40	551	546	527	496	452	390	301	245	
A 22-53	30	40	573	567	548	515	469	405	317	254	
A 22-55	37	50	595	589	569	534	486	420	329	264	
A 22-58	37	50	627	621	600	563	512	442	346	278	
A 22-60	37	50	649	642	620	582	529	457	357	287	

HEAD IN METERS

Pump Type	Motor Dia.	Dimensions (mm)			Net Weight (Kg) Pump
		A	C*	C**	
A 22-1	4"	343	131		5.0
A 22-2	4"	403	131		6.4
A 22-3	4"	464	131		7.9
A 22-4	4"	524	131		9.3
A 22-5	4"	585	131		10.8
A 22-6	4"	645	131		12.2
A 22-7	4"	706	131		13.7
A 22-8	4"	766	131		15.1
A 22-9	4"	827	131		16.6
A 22-10	4"	887	131		18.0
A 22-11	6"	948	142	142	19.5
A 22-12	6"	1008	142	142	20.9
A 22-13	6"	1069	142	142	22.4
A 22-14	6"	1129	142	142	23.9
A 22-15	6"	1190	142	142	25.3
A 22-16	6"	1250	142	142	26.8
A 22-17	6"	1311	142	142	28.2
A 22-18	6"	1371	142	142	29.7
A 22-19	6"	1432	142	142	31.1
A 22-20	6"	1492	142	142	32.5
A 22-21	6"	1553	142	142	34.0
A 22-22	6"	1613	142	142	35.4
A 22-23	6"	1674	142	142	36.9
A 22-24	6"	1734	142	142	38.3
A 22-25	6"	1795	142	142	39.8
A 22-26	6"	1855	142	142	41.2
A 22-27	6"	1916	142	142	42.7
A 22-28	6"	1976	142	142	44.2
A 22-29	6"	2037	142	142	45.6
A 22-30	6"	2097	142	142	47.1
A 22-31	6"	2158	142	142	48.5
A 22-32	6"	2218	142	142	50.0
A 22-33	6"	2279	142	142	51.4
A 22-34	6"	2339	142	142	52.9
A 22-35	6"	2400	142	142	54.3
A 22-36	6"	2460	142	142	55.7
A 22-37	6"	2521	142	142	57.2
A 22-38	6"	2581	142	142	58.6
A 22-39	6"	2642	142	142	60.1
A 22-40	6"	2702	142	142	61.5
A 22-43	6"	3255	178	181	121.7
A 22-45	6"	3376	178	181	126.1
A 22-48	6"	3558	178	181	132.6
A 22-51	6"	3739	178	181	139.1
A 22-53	6"	3860	178	181	143.4
A 22-55	6"	3981	178	181	147.8
A 22-58	6"	4163	178	181	154.3
A 22-60	6"	4284	178	181	158.6

*Higher pressure , longer stages pumps up to 60 stages are available on request.

▶ With Sleeve .

C*: Maximum diameter of pump with one motor cable
 C**: Maximum diameter of pump with two motor cable
 SP-9043 to SP-9060 are mounted in sleeve for R 3 connection
 ▶ With Sleeve .

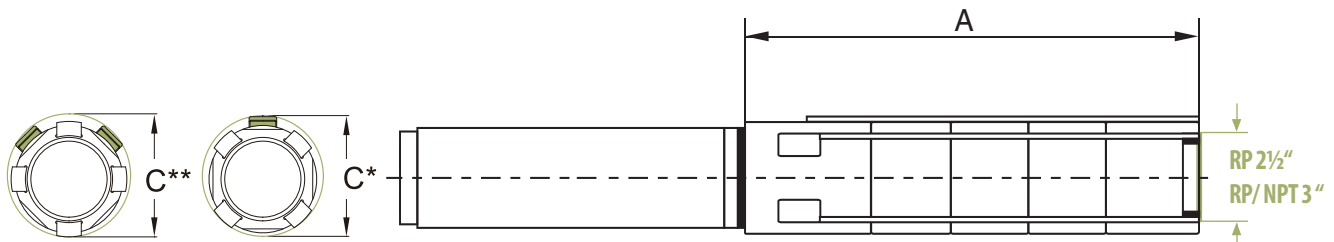

SPEED A Series

A 6"

A-33

Performance Curves

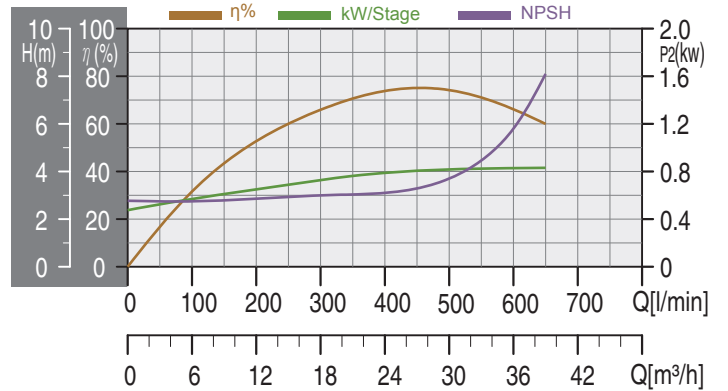
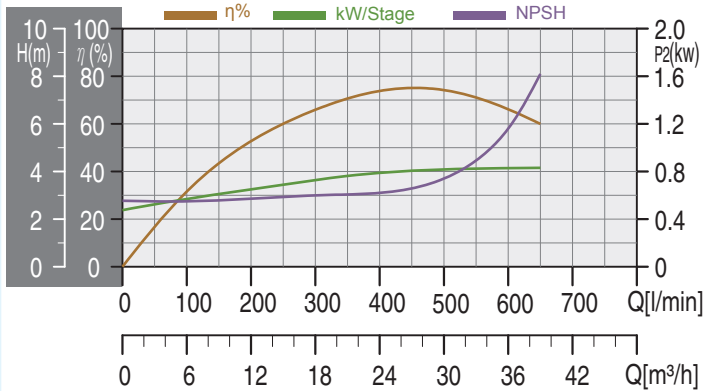
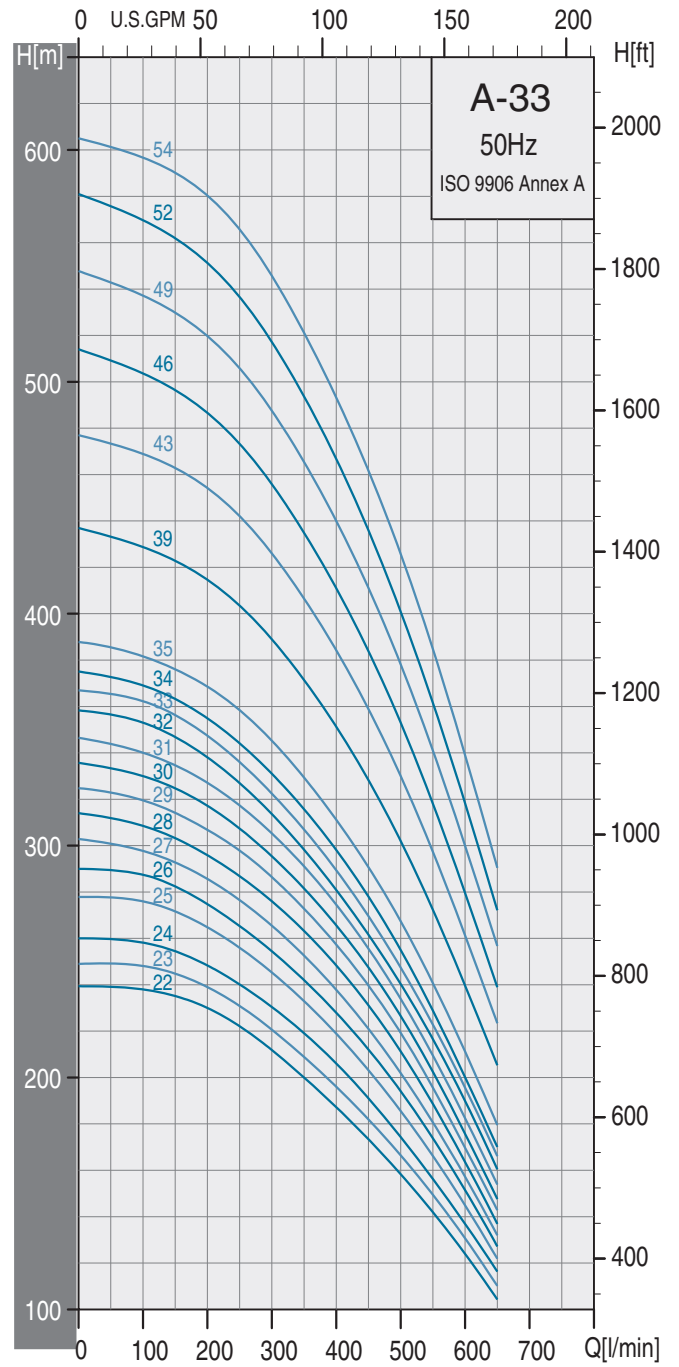
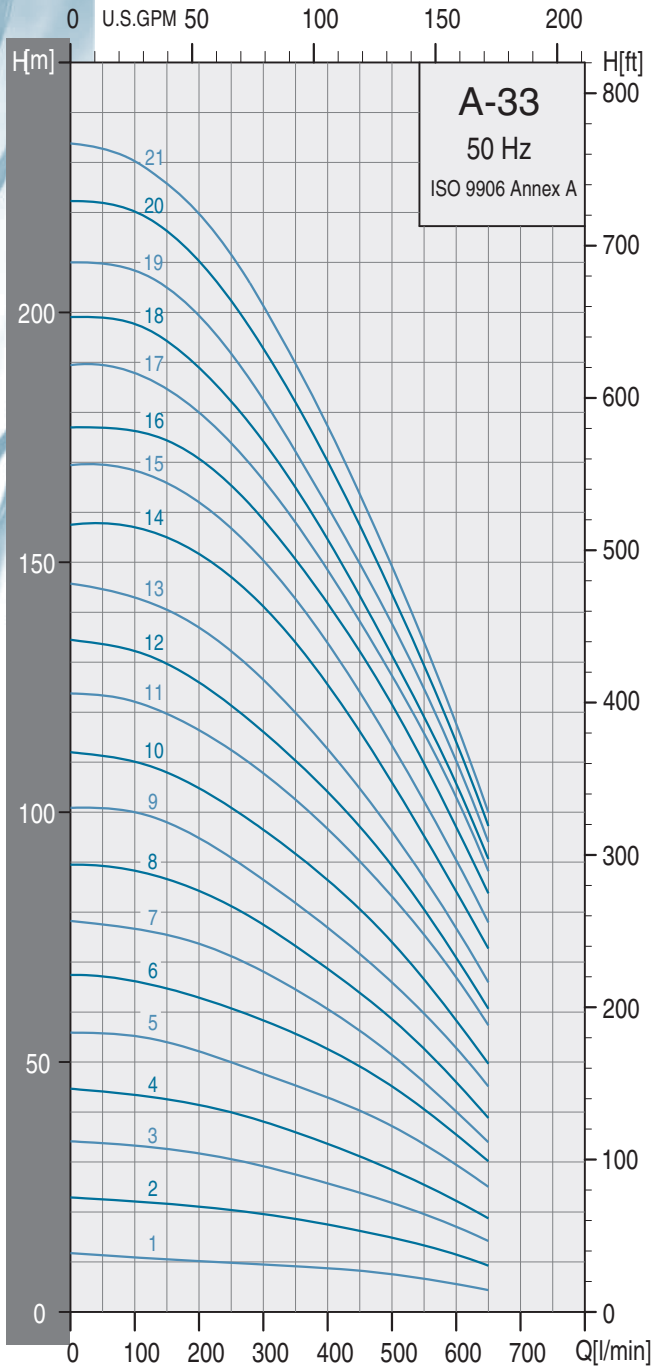

Selection Chart

50Hz

Dimensions and weights

Pump Type	Motor		Q capacity 2850 rpm												
	P2		m³/h l/min	6	9	12	15	18	21	24	27	30	33	36	39
	KW	HP		100	150	200	250	300	350	400	450	500	550	600	650
A 33-1	1.1	1.5	11	11	10	10	10	9	9	8	8	7	6	5	
A 33-2	2.2	3	23	22	21	20	19	18	17	16	15	13	11	9	
A 33-3	3	4	33	32	31	30	29	28	26	24	22	20	17	14	
A 33-4	3.7	5	43	42	41	40	38	36	34	31	28	26	23	19	
A 33-5	5.5	7.5	55	54	52	50	48	45	43	40	37	34	29	25	
A 33-6	5.5	7.5	67	64	62	60	58	56	52	49	45	40	36	30	
A 33-7	7.5	10	77	76	74	71	68	65	61	56	52	46	40	34	
A 33-8	7.5	10	88	87	84	81	78	73	68	64	58	53	46	38	
A 33-9	9.3	12.5	100	98	95	91	87	82	77	72	66	60	53	45	
A 33-10	9.3	12.5	110	108	105	101	97	92	86	81	74	67	58	50	
A 33-11	11	15	122	120	117	112	108	102	97	90	83	76	67	57	
A 33-12	11	15	132	130	126	121	116	110	104	97	89	81	71	61	
A 33-13	11	15	143	140	137	132	127	120	113	105	97	87	77	66	
A 33-14	13	17.5	157	155	152	147	141	134	126	116	108	95	84	73	
A 33-15	15	20	168	166	162	157	150	142	134	124	113	102	90	77	
A 33-16	15	20	176	174	171	165	159	151	142	132	122	110	97	84	
A 33-17	15	20	188	185	180	173	167	158	148	138	127	116	103	88	
A 33-18	18.5	25	198	194	189	182	174	165	155	143	130	119	106	90	
A 33-19	18.5	25	208	205	199	192	182	172	161	150	137	125	110	94	
A 33-20	18.5	25	220	216	210	202	193	182	170	157	144	129	114	97	
A 33-21	18.5	25	230	226	220	212	202	190	177	164	149	134	117	100	
A 33-22	22	30	238	235	230	222	212	200	187	173	159	142	124	104	
A 33-23	22	30	248	245	239	231	221	209	196	182	167	150	131	110	
A 33-24	22	30	258	254	248	240	230	219	207	191	175	156	137	117	
A 33-25	22	30	276	272	265	256	245	233	219	203	187	166	145	122	
A 33-26	22	30	287	282	275	266	255	242	227	212	194	173	152	127	
A 33-27	26	35	298	293	286	277	265	253	238	221	202	181	157	132	
A 33-28	26	35	309	303	296	287	276	263	248	231	212	189	164	137	
A 33-29	26	35	319	314	307	298	287	273	257	240	220	196	170	143	
A 33-30	26	35	330	325	317	307	295	282	266	248	227	202	176	148	
A 33-31	26	35	340	335	327	317	305	291	275	256	234	209	183	154	
A 33-32	30	40	353	347	338	327	313	298	281	261	240	217	190	160	
A 33-33	30	40	362	356	347	336	322	307	289	270	248	223	196	166	
A 33-34	30	40	369	363	355	344	331	316	298	278	255	229	200	170	
A 33-35	30	40	382	377	368	358	346	329	311	290	267	240	211	180	
A 33-39	37	50	429	423	415	404	389	371	351	328	302	272	240	205	
A 33-43	37	50	469	463	454	442	426	407	384	359	330	297	261	223	
A 33-46	45	60	503	496	487	473	456	435	411	384	353	318	280	239	
A 33-49	45	60	537	530	520	506	488	465	440	411	378	341	300	257	
A 33-52	55	75	569	562	551	537	517	494	467	436	401	362	318	272	
A 33-54	55	75	596	590	580	566	546	521	493	462	428	385	339	290	

Pump Type	Motor Dia.	Dimensions (mm)			Net Weight (Kg)
		A	C*	C**	
A 33-1	4"	366	131		6.7
A 33-2	4"	462	131		8.4
A 33-3	4"	558	131		10.1
A 33-4	4"	654	131		11.8
A 33-5	4"	750	131		13.5
A 33-6	4"	846	131		15.2
A 33-7	6"	942	142	142	16.9
A 33-8	6"	1038	142	142	18.6
A 33-9	6"	1134	142	142	20.3
A 33-10	6"	1230	142	142	22
A 33-11	6"	1326	142	142	23.6
A 33-12	6"	1422	142	142	25.3
A 33-13	6"	1518	142	142	27
A 33-14	6"	1614	142	142	29.7
A 33-15	6"	1710	142	142	30.4
A 33-16	6"	1806	142	142	32.1
A 33-17	6"	1902	142	142	33.8
A 33-18	6"	1998	142	142	35.5
A 33-19	6"	2094	142	142	37.2
A 33-20	6"	2190	142	142	38.9
A 33-21	6"	2286	142	142	40.6
A 33-22	6"	2382	142	142	42.3
A 33-23	6"	2478	142	142	44
A 33-24	6"	2574	142	142	45.6
A 33-25	6"	2670	142	142	47.3
A 33-26	6"	2766	142	142	49
A 33-27	6"	2862	142	142	50.7
A 33-28	6"	2958	142	142	52.4
A 33-29	6"	3054	142	142	54.1
A 33-30	6"	3150	142	142	55.8
A 33-31	6"	3246	142	142	57.5
A 33-32	6"	3342	142	142	59.2
A 33-33	6"	3438	142	142	60.9
A 33-34	6"	3534	142	142	62.6
A 33-35	6"	3630	142	142	64.3
A 33-39	6"	4451	178	181	142
A 33-43	6"	4775	178	181	151.2
A 33-46	8"	5016	192	192	190.8
A 33-49	8"	5304	192	192	198.1
A 33-52	8"	5592	192	192	213.5
A 33-54	8"	5784	192	192	220

*Higher pressure , longer stages pumps up to 54 stages are available on request.

▶ With Sleeve .

C*: Maximum diameter of pump with one motor cable
 C**: Maximum diameter of pump with two motor cable
 SP-15039 to SP-15054 are mounted in sleeve for R 3 connection

▶ With Sleeve .

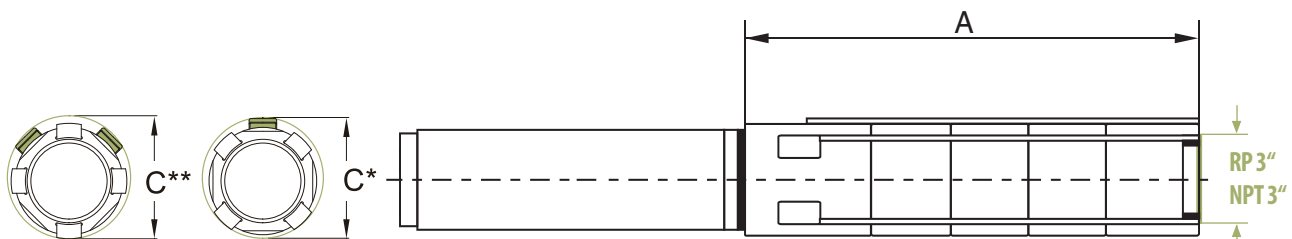

SPEED A Series

A 6"

A-55

Performance Curves

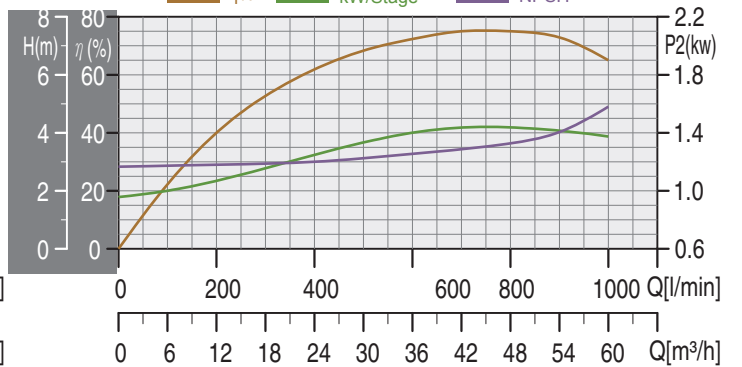
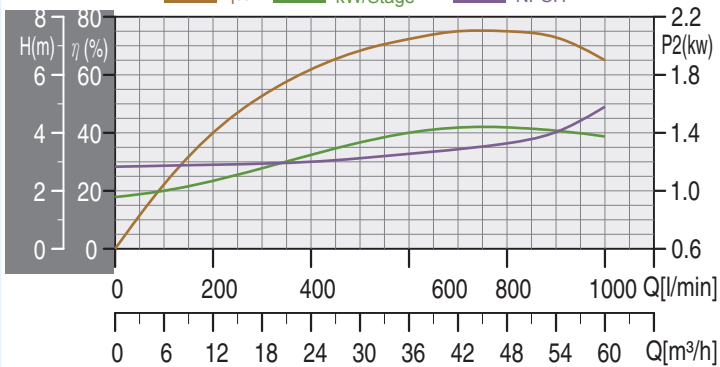
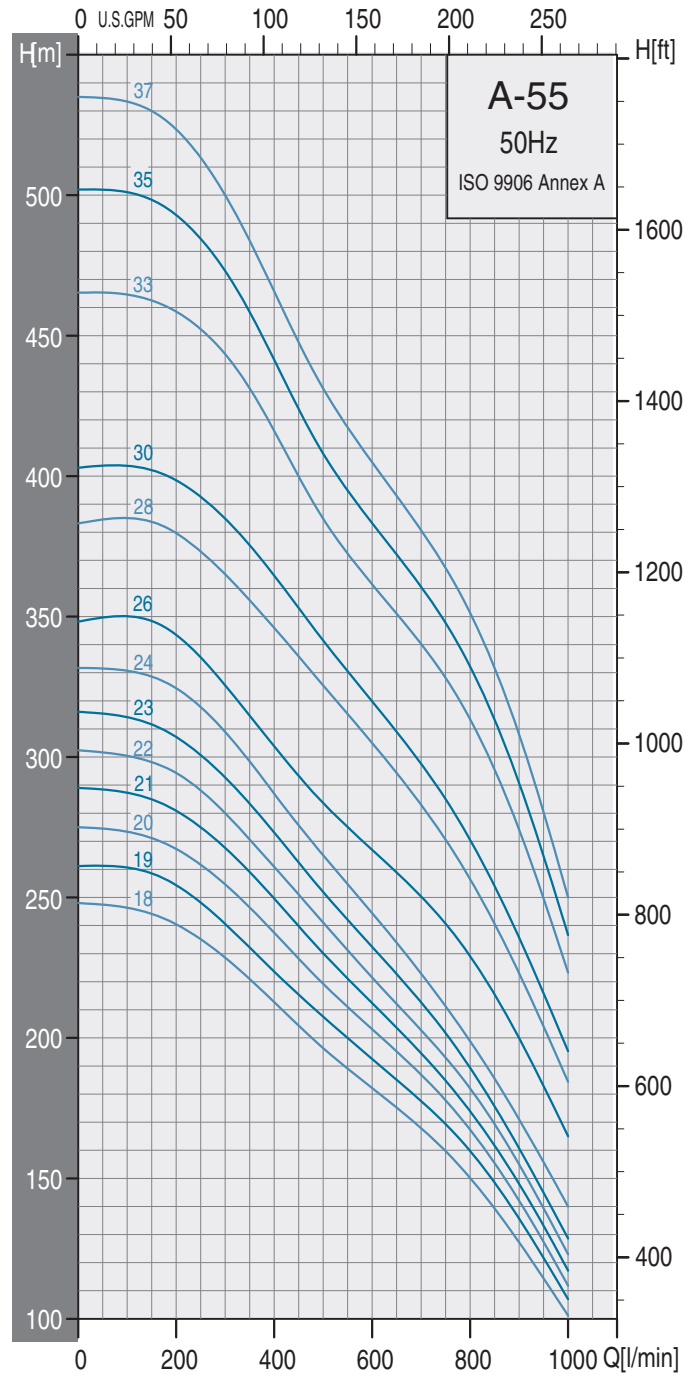
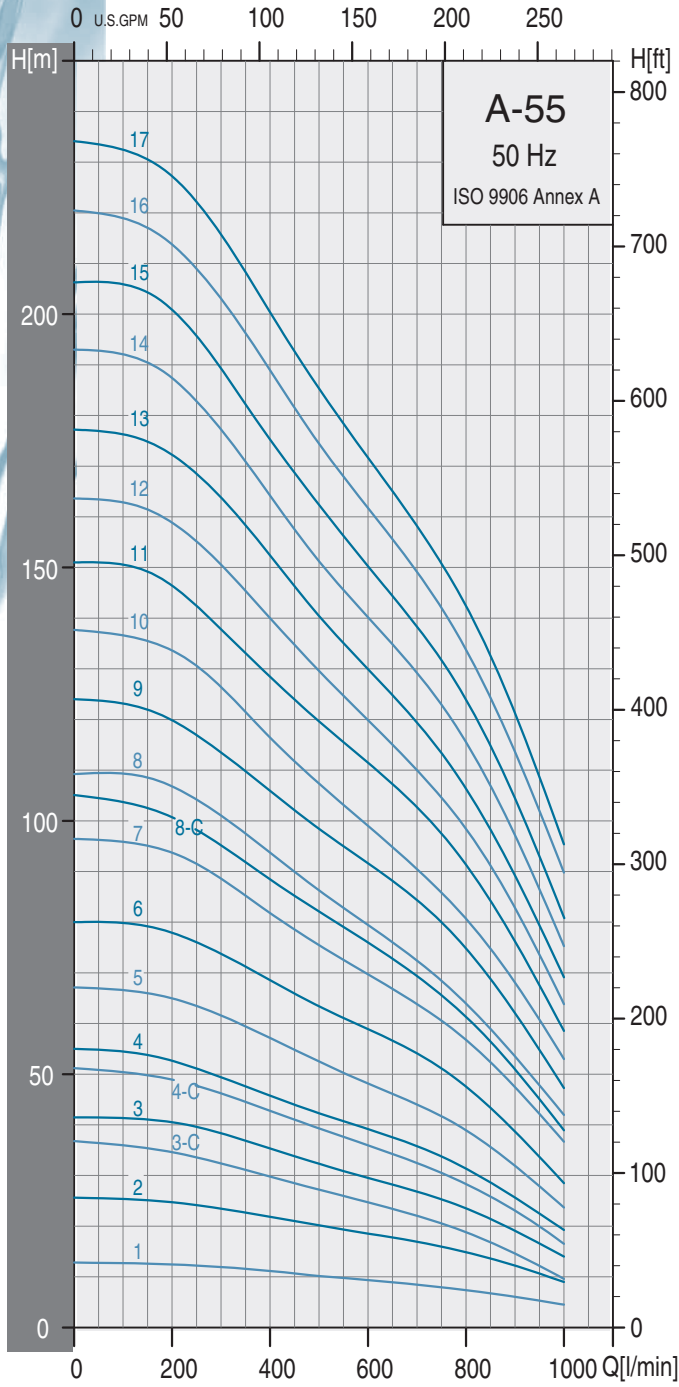

Selection Chart

50Hz

Pump Type	Motor		m³/h l/min	Q capacity 2850 rpm											
	P2			12	15	18	21	24	27	30	36	42	48	54	60
	KW	HP		200	250	300	350	400	450	500	600	700	800	900	1000
A 55-1	2.2	3	HEAD IN METERS	13	13	12	12	11	11	10	9	9	8	6	5
A 55-2	3	4		24	24	23	23	22	21	20	18	17	15	12	9
A 55-3C	3.7	5		35	34	32	31	29	28	27	24	22	19	14	10
A 55-3	5.5	7.5		40	39	38	37	35	34	33	29	27	23	18	24
A 55-4C	5.5	7.5		49	47	46	45	43	41	39	36	32	28	23	17
A 55-4	7.5	10		53	51	49	48	46	44	42	39	36	31	26	19
A 55-5	7.5	10		65	63	61	59	57	55	53	48	44	39	32	24
A 55-6	9.3	12.5		78	76	74	71	69	66	63	59	54	48	39	29
A 55-7	11	15		94	92	88	85	82	79	76	70	64	57	47	37
A 55-8C	11	15		100	98	95	92	88	85	82	76	69	61	51	39
A 55-8	13	17.5		107	104	101	97	94	90	86	79	73	64	54	42
A 55-9	15	20		120	117	114	110	106	102	98	92	85	75	62	47
A 55-10	15	20		133	130	127	122	117	112	107	98	90	80	67	53
A 55-11	18.5	25		146	142	138	133	128	124	120	112	103	91	76	59
A 55-12	18.5	25		158	155	150	145	140	135	130	120	110	98	83	64
A 55-13	22	30		172	169	164	158	152	146	140	130	120	106	89	69
A 55-14	22	30		187	183	177	171	164	158	151	140	129	115	97	75
A 55-15	22	30		200	195	189	183	176	169	163	150	138	124	103	81
A 55-16	26	35		214	209	203	196	189	182	174	162	149	134	113	90
A 55-17	26	35		227	222	215	208	200	193	186	172	158	143	121	96
A 55-18	30	40		240	235	229	221	213	204	196	182	168	150	127	101
A 55-19	30	40		254	248	241	233	224	216	208	193	178	160	136	107
A 55-20	30	40		267	262	255	246	238	228	219	203	187	167	142	112
A 55-21	37	50		280	275	268	259	250	240	230	212	195	174	148	117
A 55-22	37	50		294	288	280	270	260	251	241	222	203	183	155	123
A 55-23	37	50		307	301	293	283	273	262	252	232	213	189	161	129
A 55-24	37	50		325	317	309	298	287	276	265	244	223	199	171	140
A 55-26	45	60		343	335	324	313	302	292	283	267	251	230	200	165
A 55-28	45	60		380	373	365	356	346	336	326	305	283	257	223	184
A 55-30	45	60		398	393	385	375	365	353	342	320	298	271	236	195
A 55-33	55	75		459	452	443	431	416	400	385	362	340	313	274	223
A 55-35	55	75		493	485	473	459	441	424	408	383	361	332	291	237
A 55-37	63	85		523	513	500	484	466	448	431	405	381	351	308	250

*Higher pressure , longer stages pumps up to 37 stages are available on request.

▶ With Sleeve .

Dimensions and weights

Pump Type	Motor Dia.	Dimensions (mm)			Net Weight (Kg) Pump
		A	C*	C**	
A 55-1	4"	383	146		6.9
A 55-2	4"	496	146		9.2
A 55-3C	4"	609	146		11.5
A 55-3	4"	609	146		11.5
A 55-4C	4"	722	146		13.8
A 55-4	6"	722	149	152	13.8
A 55-5	6"	835	149	152	16
A 55-6	6"	948	149	152	18.3
A 55-7	6"	1061	149	152	20.6
A 55-8C	6"	1174	149	152	22.9
A 55-8	6"	1174	149	152	22.9
A 55-9	6"	1287	149	152	25.2
A 55-10	6"	1400	149	152	27.4
A 55-11	6"	1513	149	152	29.7
A 55-12	6"	1626	149	152	32
A 55-13	6"	1739	149	152	34.3
A 55-14	6"	1852	149	152	36.6
A 55-15	6"	1965	149	152	38.8
A 55-16	6"	2078	149	152	41.1
A 55-17	6"	2191	149	152	43.4
A 55-18	6"	2304	149	152	45.7
A 55-19	6"	2417	149	152	47.9
A 55-20	6"	2530	149	152	50.2
A 55-21	6"	2643	149	152	52.5
A 55-22	6"	2756	149	152	54.8
A 55-23	6"	2869	149	152	57.1
A 55-24	6"	2982	149	152	59.3
A 55-26	8"	2537	192	192	130.4
A 55-28	8"	3763	192	192	137.9
A 55-30	8"	3989	192	192	146
A 55-33	8"	4328	192	192	158.4
A 55-35	8"	4554	192	192	166.2
A 55-37	8"	4780	192	192	174

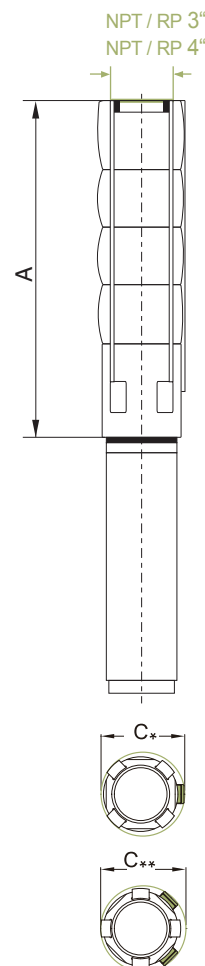

C*: Maximum diameter of pump with one motor cable
 C**: Maximum diameter of pump with two motor cable
 A 55-26 to A 55-37 are mounted in sleeve for R 4 connection

▶ With Sleeve .

SPEED A Series

A 6"

A-66

Performance Curves

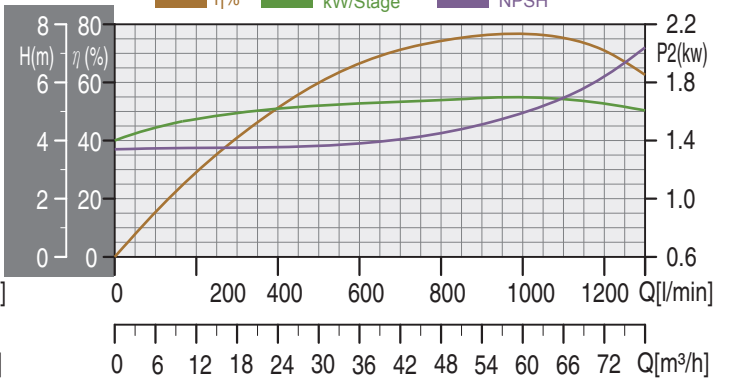
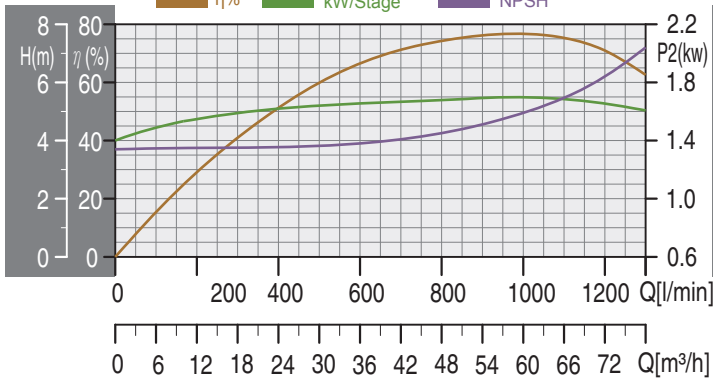
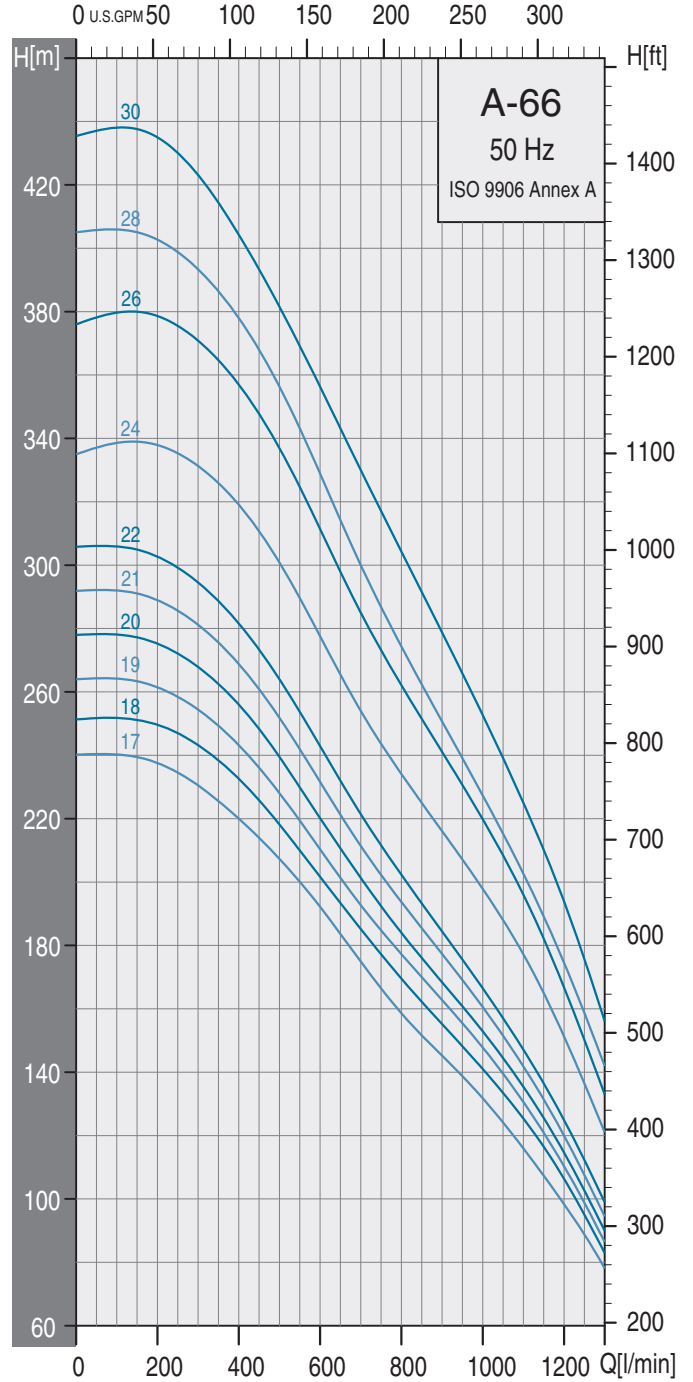
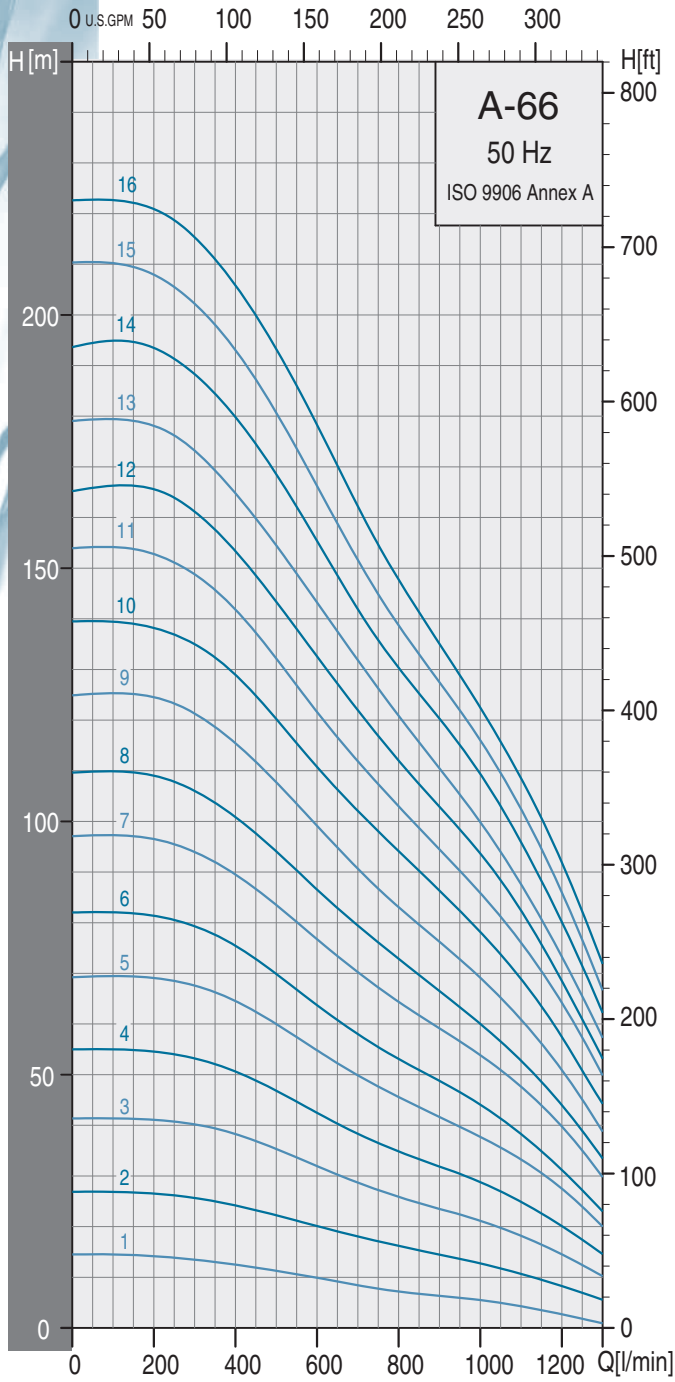

Selection Chart

50Hz

Pump Type	Motor		m³/h l/min	Q capacity 2850 rpm												
	P2			18	21	24	27	30	36	42	48	54	60	66	72	78
	KW	HP		300	350	400	450	500	600	700	800	900	1000	1100	1200	1300
A 66-1	2.2	3	HEAD IN METERS	13	13	12	12	11	10	8	7	6	5	4	2	1
A 66-2	3.7	5		26	25	24	23	22	20	18	16	14	13	11	8	5
A 66-3	5.5	7.5		40	39	38	37	36	32	28	26	24	21	18	14	10
A 66-4	7.5	10		53	52	51	48	47	43	38	35	32	28	25	20	14
A 66-5	9.3	12.5		67	66	64	52	60	55	50	46	42	38	33	27	19
A 66-6	11	15		79	78	76	73	70	64	58	53	48	44	38	32	23
A 66-7	13	17.5		94	92	89	86	84	77	70	64	59	54	47	40	29
A 66-8	15	20		106	104	101	97	94	87	80	73	67	60	53	44	33
A 66-9	18.5	25		122	118	116	112	108	99	91	83	76	69	61	51	38
A 66-10	18.5	25		135	132	128	125	120	111	102	95	87	78	68	57	45
A 66-11	22	30		148	146	142	137	132	122	112	103	95	86	76	64	49
A 66-12	22	30		162	157	153	148	143	133	122	112	103	94	83	68	53
A 66-13	26	35		173	169	165	160	155	143	132	121	110	100	87	73	57
A 66-14	26	35		188	184	180	175	168	156	142	130	120	109	96	80	63
A 66-15	26	35		203	197	193	187	180	166	152	138	127	116	103	86	67
A 66-16	30	40		216	211	206	200	193	178	162	148	135	123	108	92	72
A 66-17	37	50		230	226	220	214	207	192	175	158	145	132	116	97	78
A 66-18	37	50		243	238	233	226	218	202	185	170	155	141	126	107	83
A 66-19	37	50		254	249	243	236	228	210	193	177	163	148	131	110	86
A 66-20	37	50		267	263	256	248	239	220	201	184	168	153	136	115	90
A 66-21	37	50		281	276	269	261	252	232	211	194	177	161	142	120	95
A 66-22	37	50		295	289	282	273	264	243	221	202	184	167	147	125	99
A 66-24	45	60		331	326	319	311	301	278	254	234	216	198	177	151	121
A 66-26	55	75		371	365	357	348	337	312	285	262	241	220	196	167	133
A 66-28	55	75		393	386	378	368	357	329	300	274	251	227	203	175	142
A 66-30	55	75		423	415	404	393	381	356	330	304	279	253	225	194	156

*Higher pressure , longer stages pumps up to 30 stages are available on request.

▶ With Sleeve .

Dimensions and weights

Pump Type	Motor Dia.	Dimensions (mm)			Net Weight (Kg) Pump
		A	C*	C**	
A 66-1	6"	383	146		6.9
A 66-2	6"	496	146		9.2
A 66-3	6"	609	146		11.5
A 66-4	6"	722	149	152	13.7
A 66-5	6"	835	149	152	16.0
A 66-6	6"	948	149	152	18.3
A 66-7	6"	1061	149	152	20.6
A 66-8	6"	1174	149	152	22.9
A 66-9	6"	1287	149	152	25.1
A 66-10	6"	1400	149	152	27.4
A 66-11	6"	1513	149	152	29.7
A 66-12	6"	1626	149	152	32.0
A 66-13	6"	1739	149	152	34.3
A 66-14	6"	1852	149	152	36.5
A 66-15	6"	1965	149	152	38.8
A 66-16	6"	2078	149	152	41.1
A 66-17	6"	2191	149	152	43.4
A 66-18	6"	2304	149	152	45.7
A 66-19	6"	2417	149	152	48.0
A 66-20	6"	2530	149	152	50.2
A 66-21	6"	2643	149	152	52.5
A 66-22	8"	2784	183	183	60.2
A 66-24	8"	3311	192	192	125.1
A 66-26	8"	3537	192	192	132.4
A 66-28	8"	3763	192	192	139.9
A 66-30	8"	3989	192	192	148.0

C*: Maximum diameter of pump with one motor cable

C**: Maximum diameter of pump with two motor cable

A 66-24 and A 66-30 are mounted in sleeve for R 4 connection

▶ With Sleeve .

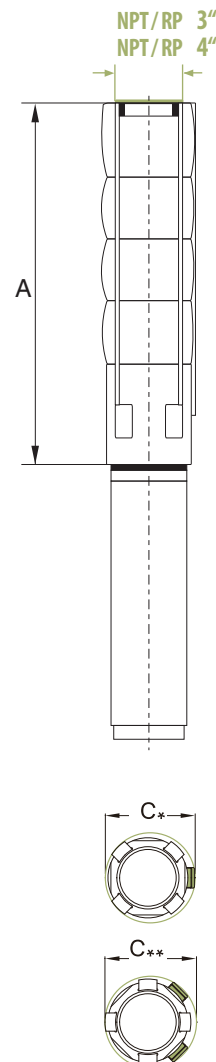

SPEED A Series

A 8"

A-88

Performance Curves

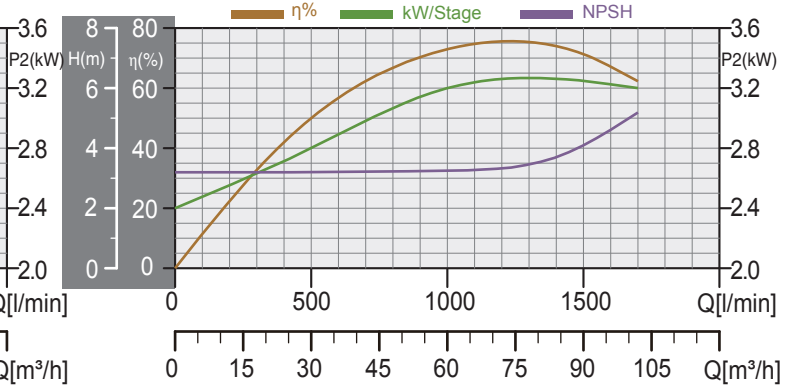
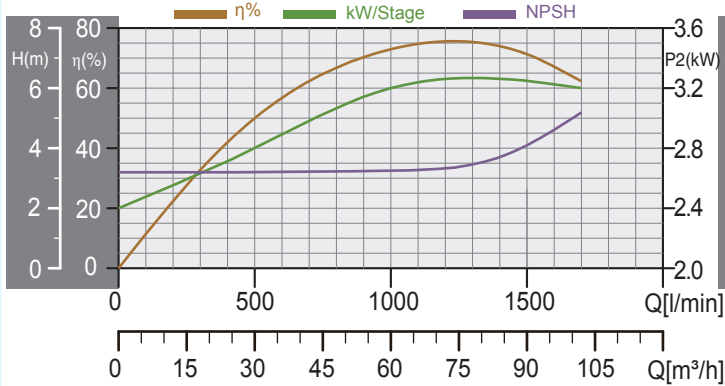
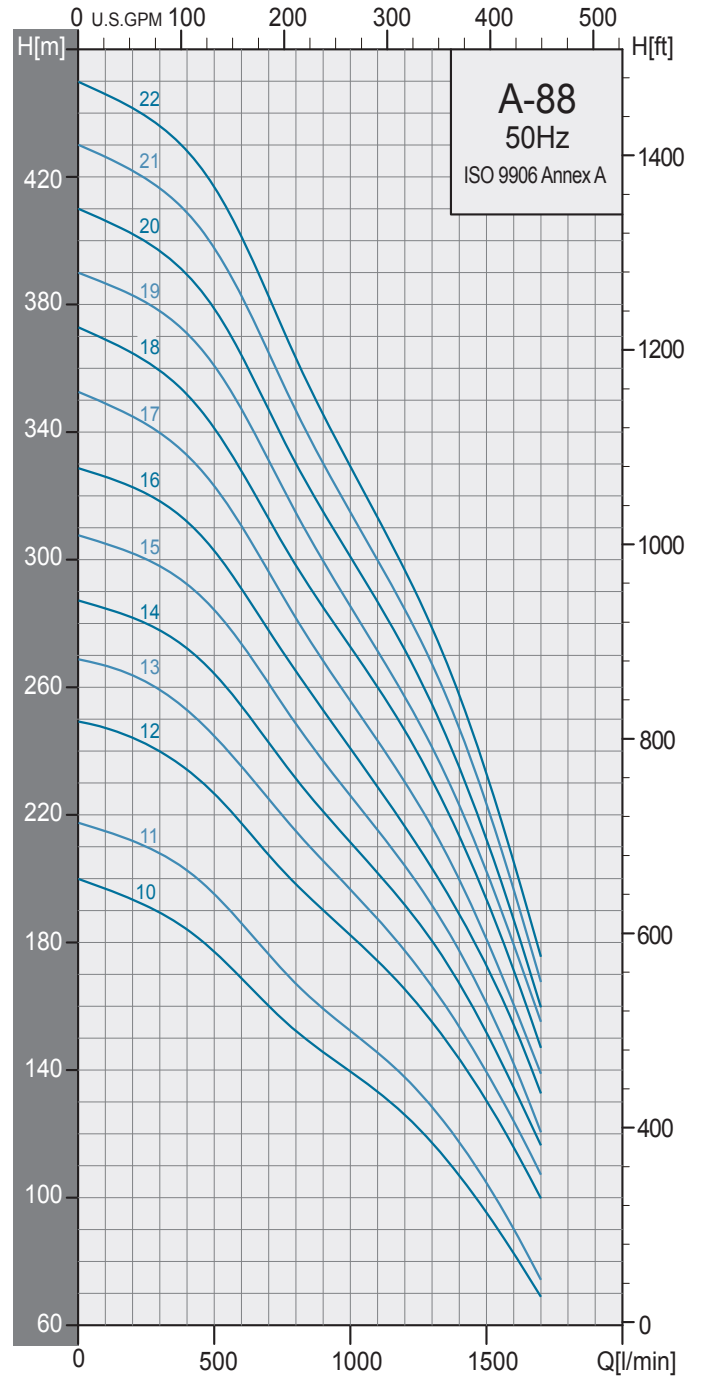
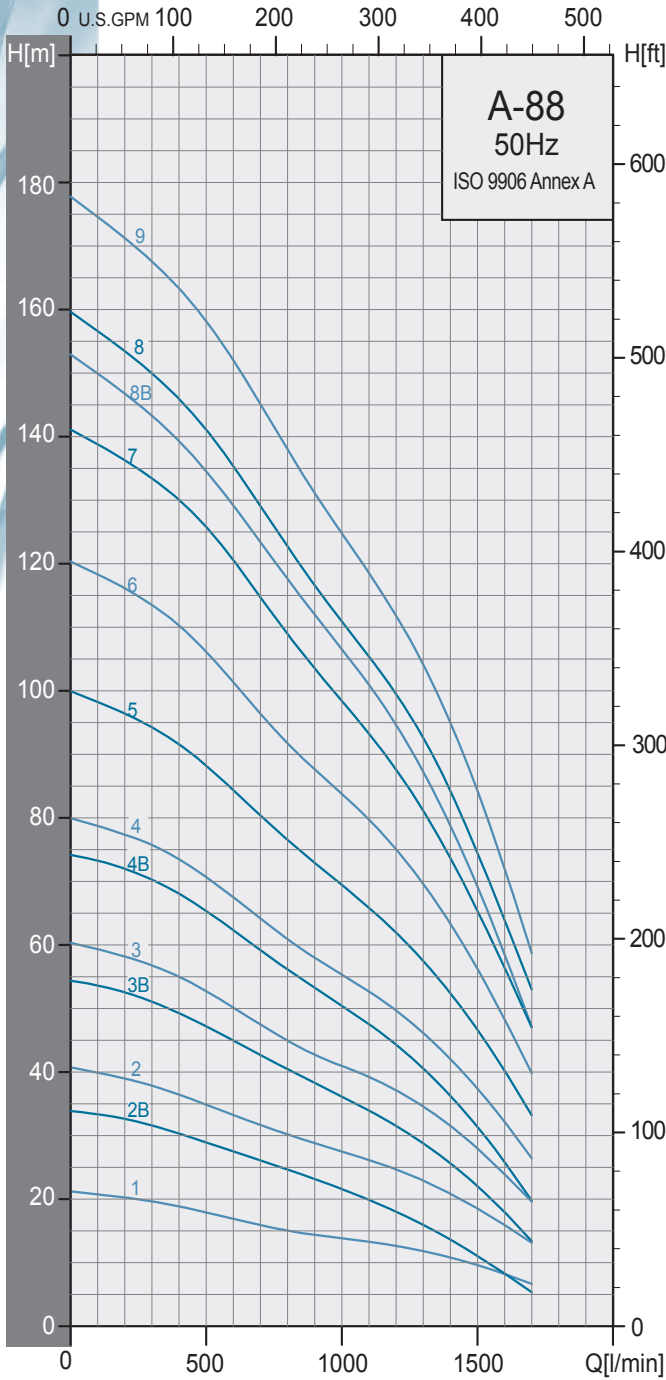

Selection Chart

50Hz

Pump Type	Motor		m³/h l/min	Q capacity 2850 rpm											
	P2			12	18	24	30	36	42	48	54	66	78	90	102
	KW	HP		200	300	400	500	600	700	800	900	1100	1300	1500	1700
A 88-1	5.5	7.5	20	20	19	18	17	16	15	14	13	12	9	7	
A 88-2B	5.5	7.5	33	32	30	28	27	26	25	23	20	16	11	6	
A 88-2	7.5	10	38	37	36	35	33	32	30	28	26	23	18	13	
A 88-3B	9.3	12.5	53	51	49	47	45	43	40	38	34	28	22	13	
A 88-3	11	15	58	57	55	53	50	47	45	43	39	35	28	20	
A 88-4B	13	17.5	72	70	68	65	62	59	56	53	47	40	31	20	
A 88-4	15	20	77	76	74	71	67	64	61	58	53	46	37	27	
A 88-5	18.5	25	96	94	92	88	84	80	76	73	66	57	46	33	
A 88-6	22	30	116	113	110	106	101	96	92	88	80	70	56	40	
A 88-7	26	35	136	133	130	126	120	115	109	104	93	81	65	47	
A 88-8B	26	35	147	143	139	134	129	123	117	112	101	87	69	47	
A 88-8	30	40	153	150	146	141	135	129	123	117	105	93	75	53	
A 88-9	30	40	171	167	163	158	152	145	138	131	118	104	84	58	
A 88-10	37	50	193	188	183	177	168	160	152	145	132	117	94	68	
A 88-11	37	50	211	207	202	195	186	176	167	159	145	128	104	74	
A 88-12	45	60	244	240	234	227	217	207	198	190	173	154	130	99	
A 88-13	55	75	263	259	252	244	235	224	214	205	187	166	139	107	
A 88-14	55	75	282	278	272	264	254	242	231	221	201	180	151	116	
A 88-15	55	75	302	298	292	284	273	260	248	237	215	191	160	120	
A 88-16	63	85	322	318	312	302	290	278	265	252	228	202	172	132	
A 88-17	63	85	345	340	333	323	310	296	281	268	243	216	181	138	
A 88-18	63	85	365	359	352	341	328	312	298	285	260	230	193	147	
A 88-19	75	100	383	378	371	361	347	331	314	299	271	241	202	155	
A 88-20	75	100	402	397	389	379	364	347	330	315	287	254	212	159	
A 88-21	75	100	422	416	409	398	383	365	347	330	300	267	223	167	
A 88-22	93	125	442	436	428	417	401	382	363	345	313	278	233	175	

HEAD IN METERS

*Higher pressure , longer stages pumps up to 22 stages are available on request.

Dimensions and weights

Pump Type	Motor Dia.	Dimensions (mm)						Net Weight (Kg)
		5"Connection(RP,NPT)			5"Flange			
		A	C*	C**	A	C*	C**	
A 88-1	6"	618	178	186	618	200	200	25.1
A 88-2B	6"	746	178	186	746	200	200	28.7
A 88-2	6"	746	178	186	746	200	200	28.7
A 88-3B	6"	874	178	186	874	200	200	32.3
A 88-3	6"	874	178	186	874	200	200	32.3
A 88-4B	6"	1003	178	186	1003	200	200	35.9
A 88-4	6"	1003	178	186	1003	200	200	35.9
A 88-5	6"	1131	178	186	1131	200	200	39.5
A 88-6	6"	1259	178	186	1259	200	200	43
A 88-7	6"	1387	178	186	1387	200	200	46.6
A 88-8B	6"	1515	178	186	1515	200	200	50.2
A 88-8	6"	1515	178	186	1515	200	200	50.2
A 88-9	6"	1644	178	186	1644	200	200	53.8
A 88-10	6"	1772	178	186	1772	200	200	57.4
A 88-11	6"	1900	178	186	1900	200	200	61
A 88-12	8"	2039	200	204	2039	209	209	67
A 88-13	8"	2168	200	204	2168	209	209	70.6
A 88-14	8"	2296	200	204	2296	209	209	74.2
A 88-15	8"	2424	200	204				77.8
A 88-16	8"	2552	200	204				81.4
A 88-17	8"	2680	200	204				85.2
A 88-18	8"	2809	200	204				88.6
A 88-19	8"	2937	200	204				92.2
A 88-20	8"	3065	200	204				95.8
A 88-21	8"	3193	200	204				99.4
A 88-22	8"	3321	200	204				103

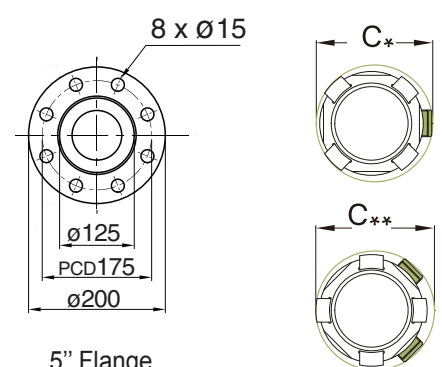
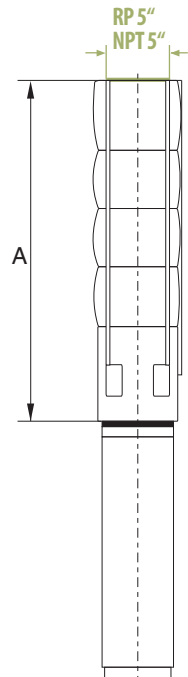

C*: Maximum diameter of pump with one motor cable
 C**: Maximum diameter of pump with two motor cable

SPEED A Series

A 8"

A-120

Performance Curves

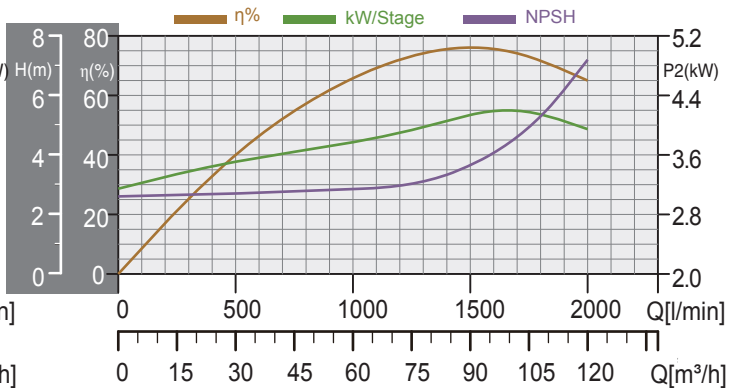
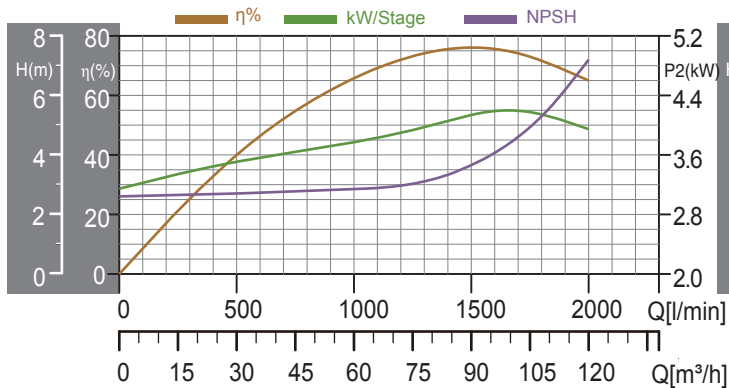
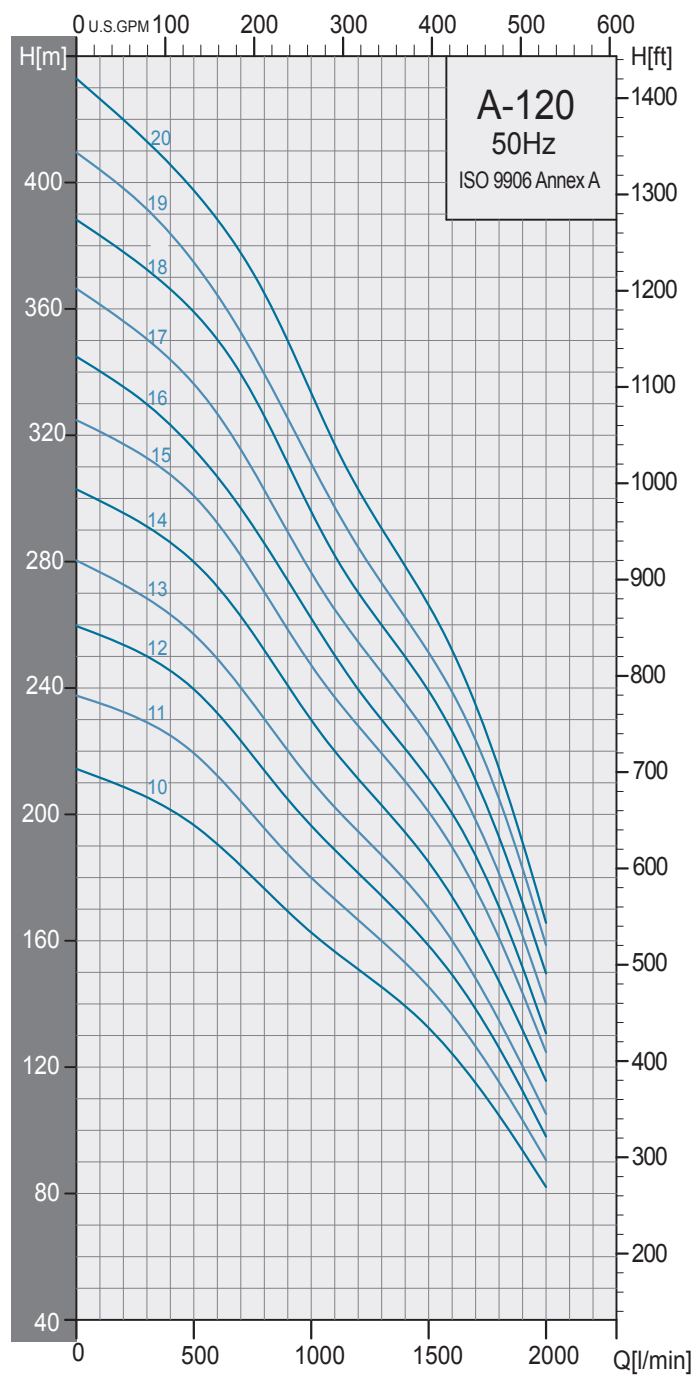
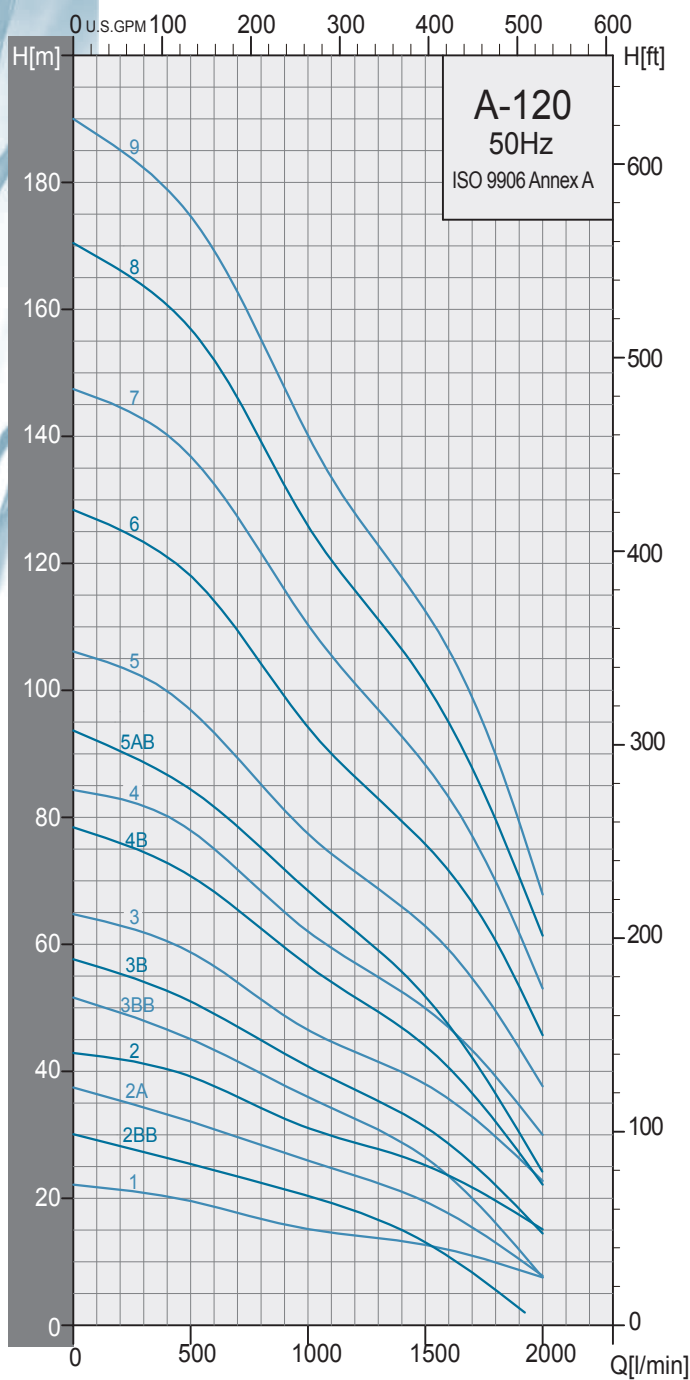

Selection Chart

50Hz

Pump Type	Motor		m³/h l/min	Q capacity 2850 rpm											
	P2			18	24	30	36	42	48	60	72	84	96	108	120
	KW	HP		300	400	500	600	700	800	1000	1200	1400	1600	1800	2000
A 120-1	5.5	7.5	HEAD IN METERS	21	20	19	18	18	17	15	14	13	12	10	8
A 120-2BB	5.5	7.5		27	26	25	24	23	22	20	18	15	11	5	-
A 120-2A	7.5	10		34	33	32	31	30	28	26	24	21	17	13	8
A 120-2	9.3	12.5		41	40	39	37	36	34	31	29	26	23	20	15
A 120-3BB	9.3	12.5		48	46	45	43	41	40	36	33	28	23	16	8
A 120-3B	11	15		54	53	51	49	47	45	41	37	33	28	22	15
A 120-3	13	17.5		62	60	59	57	54	51	47	43	40	35	30	23
A 120-4B	15	20		74	73	71	68	65	62	56	52	47	40	32	22
A 120-4	18.5	25		82	80	78	75	72	68	62	57	53	47	39	30
A 120-5AB	18.5	25		89	87	84	82	78	75	68	62	55	47	36	25
A 120-5	22	30		102	100	97	94	90	85	77	72	66	59	50	38
A 120-6	26	35		123	121	118	114	110	104	94	86	79	72	60	46
A 120-7	30	40		143	140	137	132	127	121	110	101	93	83	70	53
A 120-8	37	50		164	160	157	152	146	139	126	116	106	95	80	62
A 120-9	37	50		182	179	175	169	163	155	140	128	118	106	90	68
A 120-10	45	60		206	201	197	190	183	177	162	150	140	124	105	82
A 120-11	55	75		230	225	220	212	204	196	180	167	152	137	116	90
A 120-12	55	75		250	245	240	231	222	214	197	181	167	150	126	99
A 120-13	55	75		268	263	258	250	240	230	210	195	180	160	135	106
A 120-14	63	85		291	286	280	271	261	251	230	210	194	174	147	116
A 120-15	75	100	312	308	300	292	281	270	248	228	210	190	160	126	
A 120-16	75	100	330	323	316	307	297	286	262	240	221	200	171	131	
A 120-17	75	100	350	344	336	327	316	302	277	255	235	212	180	140	
A 120-18	93	125	372	366	360	350	340	326	296	270	250	227	192	150	
A 120-19	93	125	392	384	375	364	353	339	311	285	262	239	205	159	
A 120-20	93	125	412	406	397	388	378	365	333	302	279	251	214	166	

Dimensions and weights

Pump Type	Motor Dia.	Dimensions (mm)						Net Weight (Kg)
		5" Connection (RP, NPT)			5" Flange			
		A	C*	C**	A	C*	C**	
A 120-1	6"	618	178	186	618	200	200	25.1
A 120-2BB	6"	746	178	186	746	200	200	28.7
A 120-2A	6"	746	178	186	746	200	200	28.7
A 120-2	6"	746	178	186	746	200	200	28.7
A 120-3BB	6"	874	178	186	874	200	200	32.3
A 120-3B	6"	874	178	186	874	200	200	32.3
A 120-3	6"	874	178	186	874	200	200	32.3
A 120-4B	6"	1003	178	186	1003	200	200	35.9
A 120-4	6"	1003	178	186	1003	200	200	35.9
A 120-5AB	6"	1131	178	186	1131	200	200	39.5
A 120-5	6"	1131	178	186	1131	200	200	39.5
A 120-6	6"	1259	178	186	1259	200	200	43
A 120-7	6"	1387	178	186	1387	200	200	46.6
A 120-8	6"	1515	178	186	1515	200	200	50.2
A 120-9	6"	1644	178	186	1644	200	200	53.8
A 120-10	8"	1783	196	204	1783	205	205	60.1
A 120-11	8"	1911	196	204	1911	205	205	63.7
A 120-12	8"	2039	196	204	2039	205	205	67.3
A 120-13	8"	2168	196	204	2168	205	205	71
A 120-14	8"	2296	196	204	2296	205	205	74.6
A 120-15	8"	2424	196	204				78.2
A 120-16	8"	2552	196	204				81.8
A 120-17	8"	2680	196	204				85.4
A 120-18	8"	2809	196	204				89
A 120-19	8"	2937	196	204				92.6
A 120-20	8"	3065	196	204				96.2

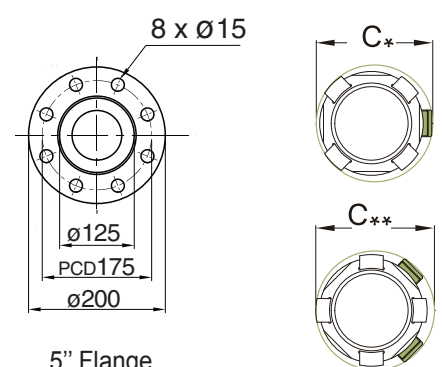
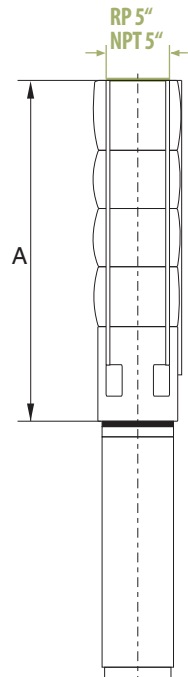

C*: Maximum diameter of pump with one motor cable
 C**: Maximum diameter of pump with two motor cable

5" Flange

SPEED A Series

A 10"

A-150

Performance Curves

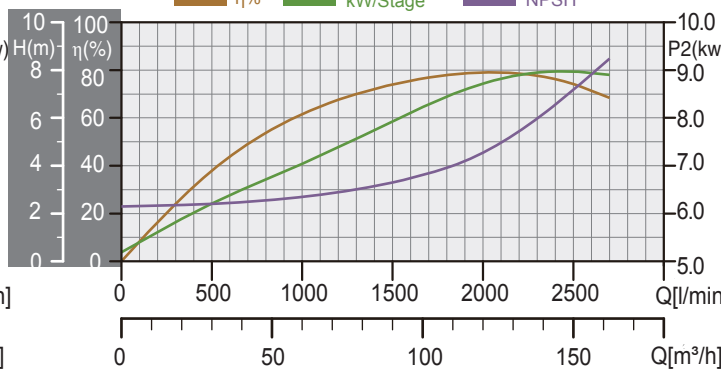
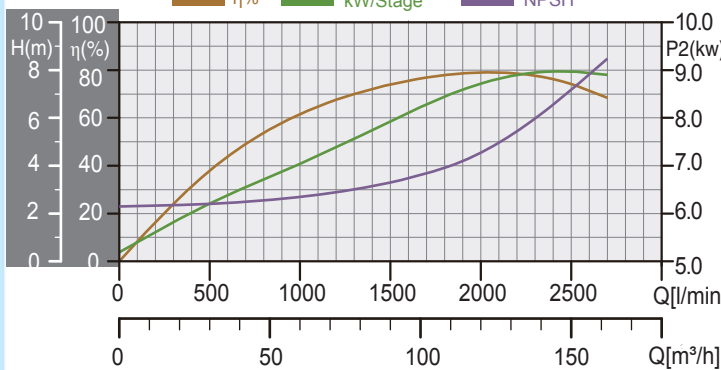
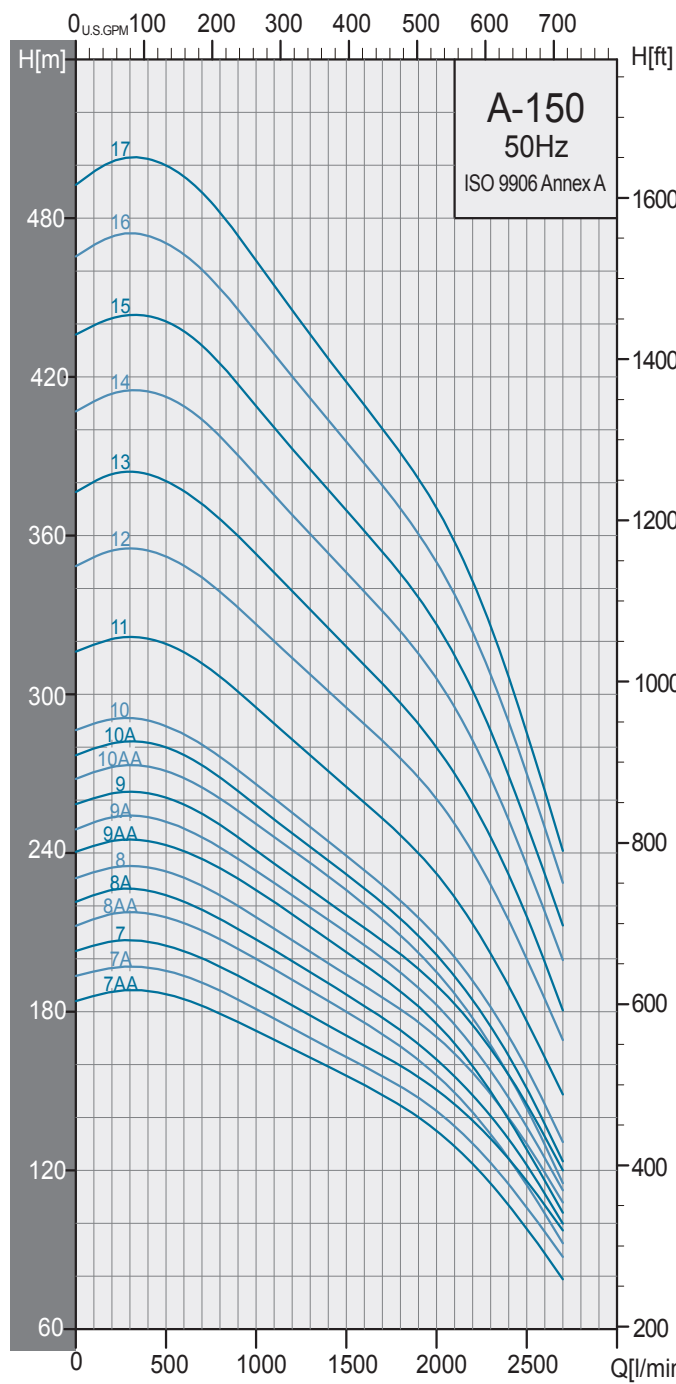
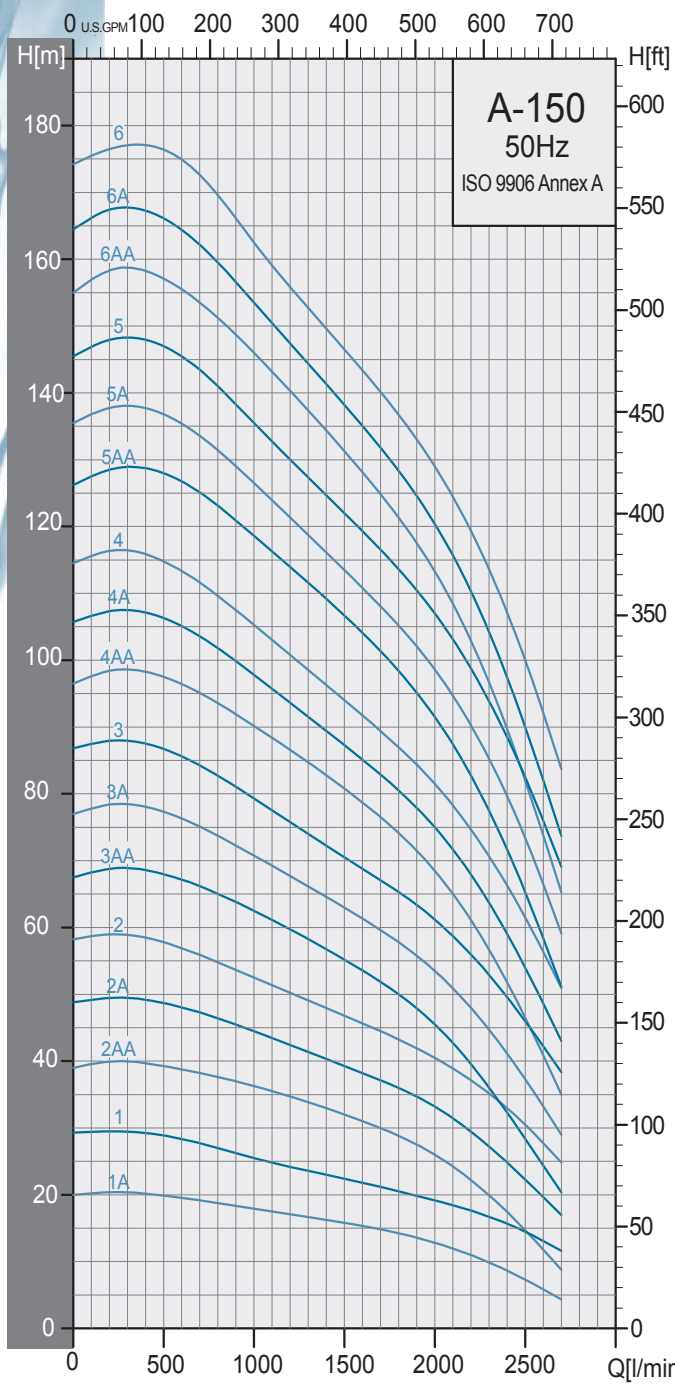

Selection Chart

50Hz

Dimensions and weights

Pump Type	Motor		Q capacity 2850 rpm												
	P2 KW	HP	m ³ /h l/min	30 500	42 700	54 900	66 1100	78 1300	90 1500	102 1700	114 1900	126 2100	138 2300	150 2500	162 2700
A150-1-A	7.5	10		20	19	18	18	17	16	15	14	12	10	7	4
A150-1	11	15		29	28	26	25	24	22	22	20	18	17	15	12
A150-2-AA	13	17.5		39	38	37	36	34	32	30	28	24	20	15	9
A150-2-A	18.5	25		49	48	46	44	41	39	38	35	32	28	22	17
A150-2	22	30		58	56	54	52	49	47	44	42	39	35	31	25
A150-3-AA	22	30		68	66	64	61	58	55	52	48	43	36	29	20
A150-3-A	26	35		77	75	73	69	66	63	60	56	51	45	37	29
A150-3	30	40		87	89	81	78	74	71	68	63	58	53	46	39
A150-4-AA	37	50		98	95	92	88	85	81	77	72	65	67	47	35
A150-4-A	37	50		106	104	100	96	92	87	83	78	72	64	54	43
A150-4	37	50		115	112	108	103	98	94	89	84	78	71	62	51
A150-5-AA	45	60		128	125	121	116	112	107	101	95	87	78	65	51
A150-5-A	45	60		137	133	129	124	119	114	108	102	95	85	73	59
A150-5	55	75		147	144	138	133	128	122	117	111	103	94	83	69
A150-6-AA	55	75		157	154	149	143	138	131	125	118	108	97	82	65
A150-6-A	55	75		166	162	156	151	144	138	132	125	116	104	90	74
A150-6	63	85		176	173	166	159	153	147	140	133	124	114	100	84
A150-7-AA	63	85		187	183	176	170	163	156	148	140	129	115	98	79
A150-7-A	63	85		196	191	185	178	170	163	155	148	137	123	106	83
A150-7	75	100		205	200	194	186	178	171	164	155	145	132	116	98
A150-8-AA	75	100		216	211	204	196	188	180	172	162	149	134	115	93
A150-8-A	75	100		224	218	212	204	195	187	178	168	156	141	122	100
A150-8	75	100		233	227	220	212	203	194	186	176	165	149	130	108
A150-9-AA	93	125		243	238	230	221	212	203	193	182	168	150	128	104
A150-9-A	93	125		252	245	237	228	219	210	200	189	175	158	137	113
A150-9	93	125		261	255	246	236	226	217	207	196	183	166	145	120
A150-10-AA	93	125		271	265	256	246	236	226	215	203	186	167	144	115
A150-10-A	93	125		280	273	264	253	243	232	221	209	193	175	151	123
A150-10	93	125		288	281	271	261	250	239	227	215	201	182	159	131
A150-11	110	150		319	312	301	289	277	265	254	240	223	202	177	149
A150-12	132	175		352	345	333	320	308	295	283	269	251	228	200	169
A150-13	132	175		381	372	360	346	332	318	304	289	270	246	216	180
A150-14	147	200		413	404	390	375	361	346	332	316	295	269	236	200
A150-15	147	200		441	431	417	401	385	370	354	336	315	286	251	213
A150-16	170	230		471	460	445	428	412	396	379	361	338	308	270	229
A150-17	170	230		500	490	473	455	436	418	406	382	358	325	286	241

HEAD IN METERS

Pump Type	Motor Dia.	Dimensions (mm)			Net Weight (Kg)
		A	C*	C**	
A150-1-A	6"	652	211	218	29.2
A150-1	6"	652	211	218	29.3
A150-2-AA	6"	807	211	218	35.6
A150-2-A	6"	807	211	218	35.7
A150-2	6"	807	211	218	35.8
A150-3-AA	6"	963	211	218	42.1
A150-3-A	6"	963	211	218	42.2
A150-3	6" 8"	963	211 213	218	42.3 47.1
A150-4-AA	6" 8"	1118	211 213	218	48.6 51.9
A150-4-A	6" 8"	1118	211 213	218	48.7 52.0
A150-4	6" 8"	1118	211 213	218	48.8 52.1
A150-5-AA	6" 8"	1274	211 213	218	55.1 56.9
A150-5-A	6" 8"	1274	211 213	218	55.2 57.0
A150-5	8"	1274	213	218	57.1
A150-6-AA	8"	1429	213	218	61.9
A150-6-A	8"	1429	213	218	62.0
A150-6	8"	1429	218	227	62.1
A150-7-AA	8"	1585	218	227	66.9
A150-7-A	8"	1585	218	227	67.0
A150-7	8"	1585	218	227	67.1
A150-8-AA	8"	1740	218	227	71.9
A150-8-A	8"	1740	218	227	72.0
A150-8	8"	1740	218	227	72.1
A150-9-AA	8"	1896	218	227	76.9
A150-9-A	8"	1896	218	227	77.0
A150-9	8"	1896	218	227	77.1
A150-10-AA	8"	2051	218	227	81.9
A150-10-A	8"	2051	218	227	82.0
A150-10	8"	2051	218	227	82.1
A150-11	8"	2207	218	227	87.1
A150-12	10"	2492	227	247	109.5
A150-13	10"	2648	227	247	116.0
A150-14	10"	2803	227	247	122.5
A150-15	10"	2959	227	247	129.0
A150-16	10"	3114	227	247	135.5
A150-17	10"	3270	227	247	142.0

C*: Maximum diameter of pump with one motor cable
 C**: Maximum diameter of pump with two motor cable

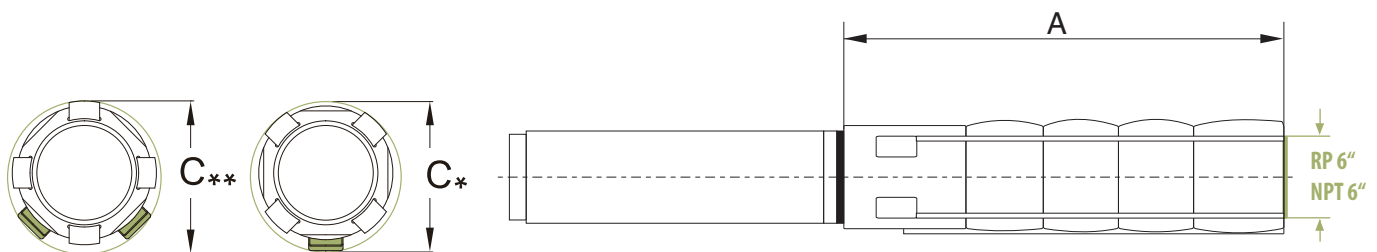

SPEED A Series

A 10"

A-200

Performance Curves

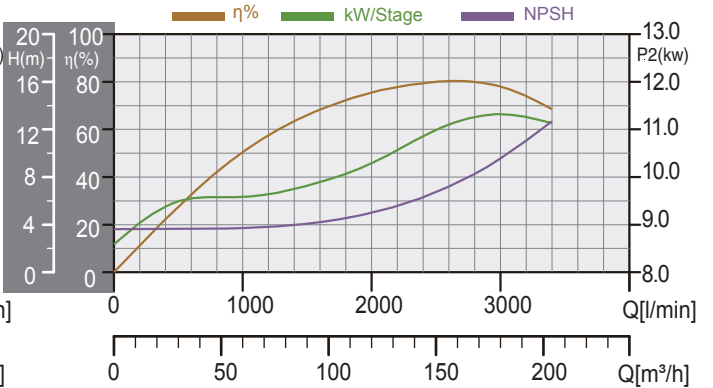
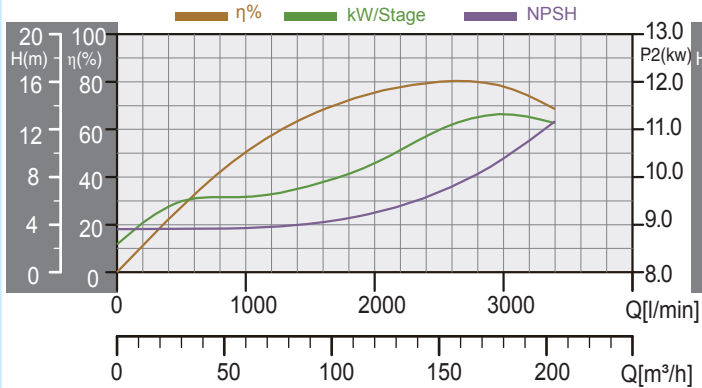
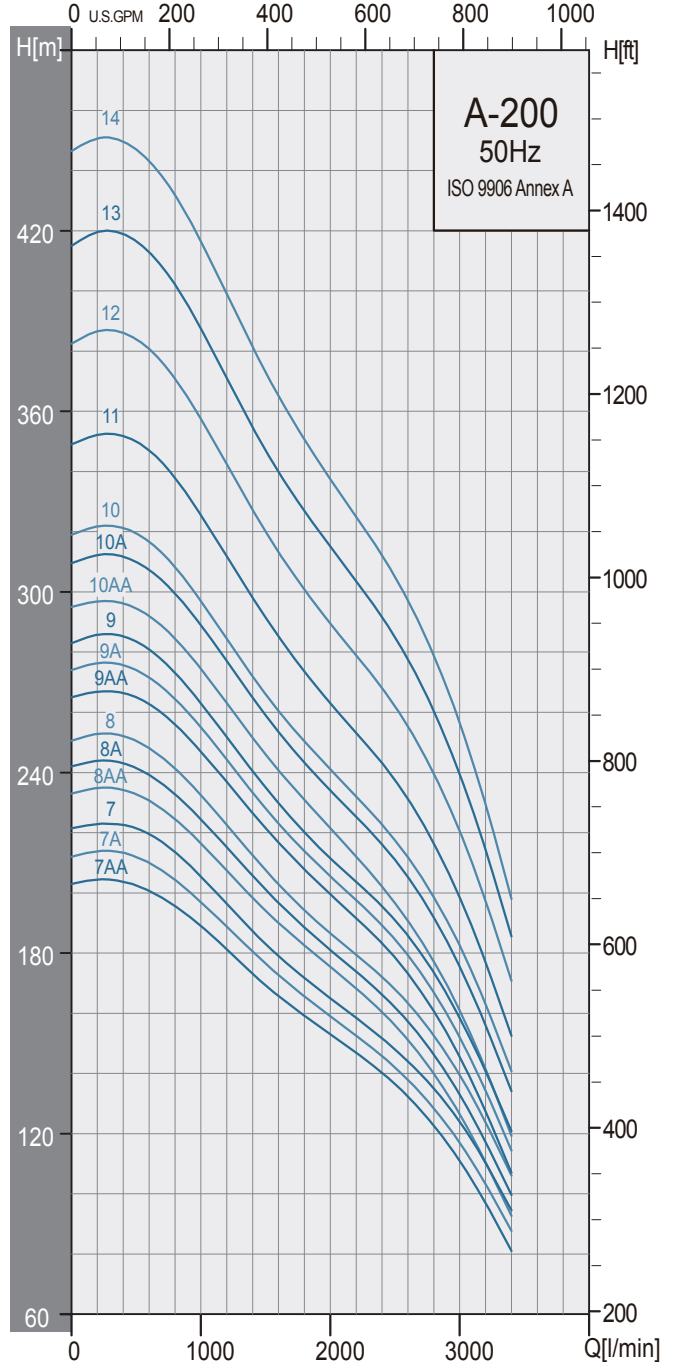
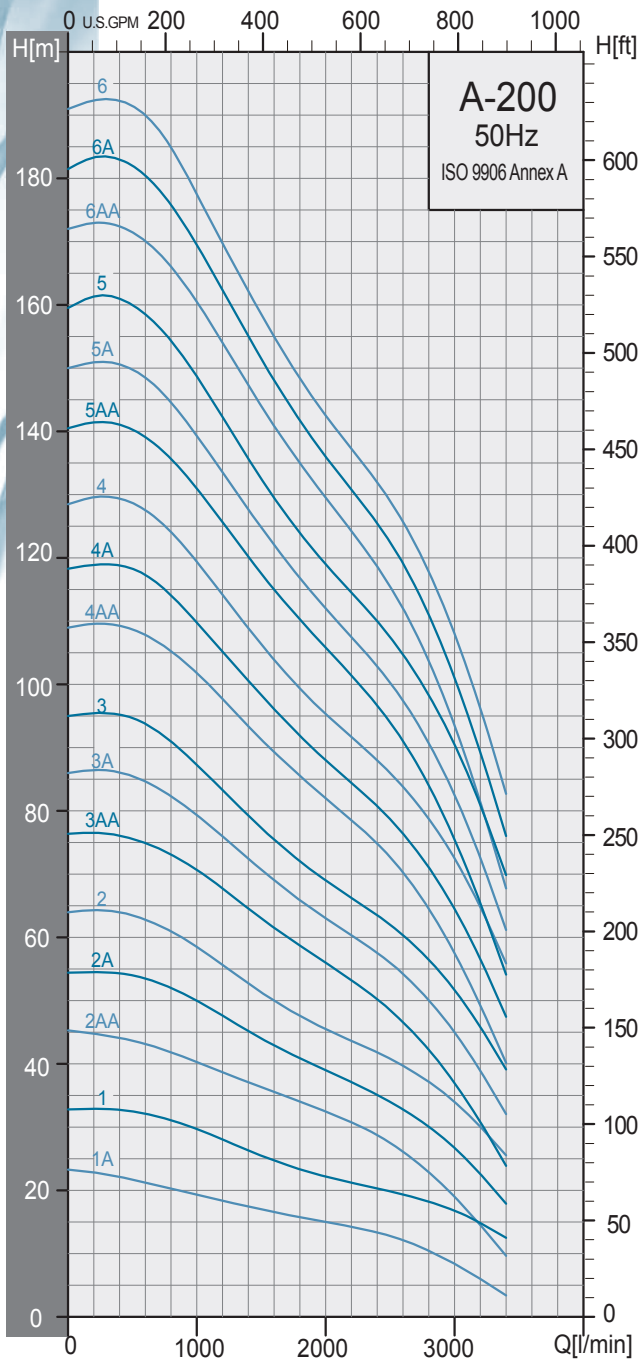

Selection Chart

50Hz

Dimensions and weights

Pump Type	Motor		Q capacity 2850 rpm										Net Weight (Kg)	
	P2		m³/h	36	54	72	90	108	126	144	162	180		198
	KW	HP	l/min	600	900	1200	1500	1800	2100	2400	2700	3000	3300	
A 200-1-A	9.2	12.5		21	20	18	17	16	15	13	12	8	5	
A 200-1	13	17.5		32	31	28	25	24	22	20	19	17	14	
A 200-2-AA	18.5	25		43	41	39	36	34	32	29	25	19	12	
A 200-2-A	22	30		53	51	48	44	41	38	35	32	27	20	
A 200-2	26	35		63	60	56	51	48	45	42	38	34	28	
A 200-3-AA	30	40		75	72	68	63	59	55	50	45	37	28	
A 200-3-A	37	50		85	81	76	71	66	62	58	52	45	36	
A 200-3	37	50		94	89	83	78	72	68	64	59	52	43	
A 200-4-AA	45	60	HEAD IN METERS	108	104	98	91	85	80	75	68	57	45	
A 200-4-A	45	60		117	112	105	98	92	86	81	74	65	52	
A 200-4	55	75		128	122	114	106	99	94	88	81	73	61	
A 200-5-AA	55	75		139	134	126	118	110	104	97	88	75	60	
A 200-5-A	55	75		148	142	134	125	117	110	103	94	82	67	
A 200-5	63	85		158	152	142	132	124	117	110	102	90	76	
A 200-6-AA	63	85		170	163	154	144	135	127	119	108	93	75	
A 200-6-A	75	100		180	173	162	152	142	133	125	115	101	83	
A 200-6	75	100		190	182	170	158	148	140	132	122	108	90	
A 200-7-AA	75	100		200	193	181	169	159	150	140	128	111	89	
A 200-7-A	92	125		210	201	188	177	166	156	146	134	117	96	
A 200-7	92	125		220	210	196	183	172	162	152	140	124	102	
A 200-8-AA	92	125		230	220	208	194	183	172	160	146	126	102	
A 200-8-A	92	125		239	229	215	201	189	177	167	152	133	108	
A 200-8	92	125	248	237	222	208	194	183	172	158	140	115		
A 200-9-AA	110	150	263	252	237	222	208	196	183	167	146	117		
A 200-9-A	110	150	272	260	244	228	214	202	189	174	152	124		
A 200-9	110	150	281	268	252	235	220	207	196	180	159	131		
A 200-10-AA	110	150	292	280	263	246	231	217	202	184	161	131		
A 200-10-A	132	175	307	295	277	259	244	230	216	199	176	145		
A 200-10	132	175	317	303	284	266	250	236	223	205	182	152		
A 200-11	132	175	347	332	312	292	274	258	243	224	199	165		
A 200-12	147	200	380	365	342	320	301	285	268	248	221	184		
A 200-13	170	230	413	395	371	347	327	309	292	269	240	200		
A 200-14	170	230	443	425	399	373	350	332	312	288	257	213		

C*: Maximum diameter of pump with one motor cable
 C**: Maximum diameter of pump with two motor cable
 - : On Request



SPEED A Series

A 10"

A-250

Performance Curves

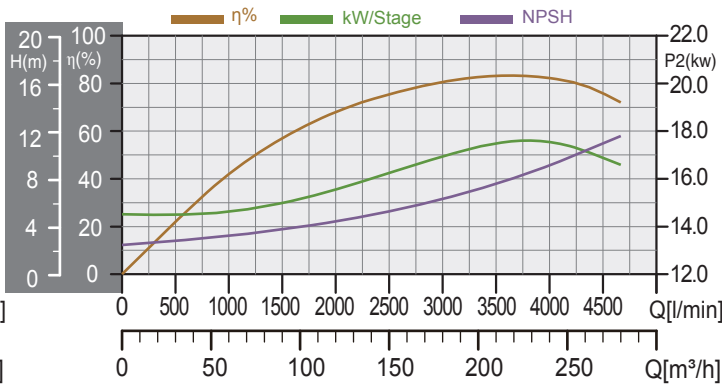
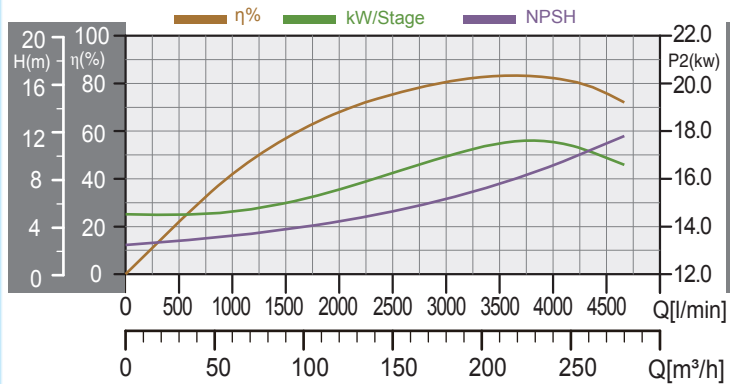
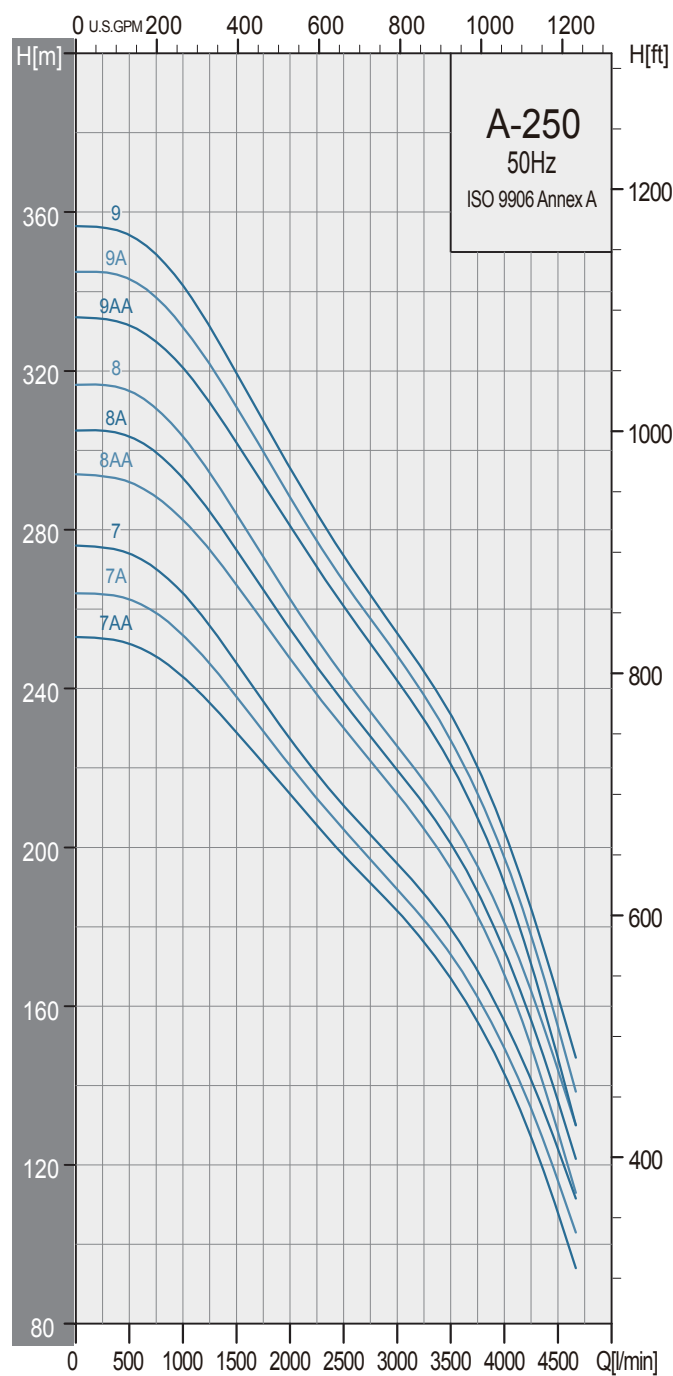
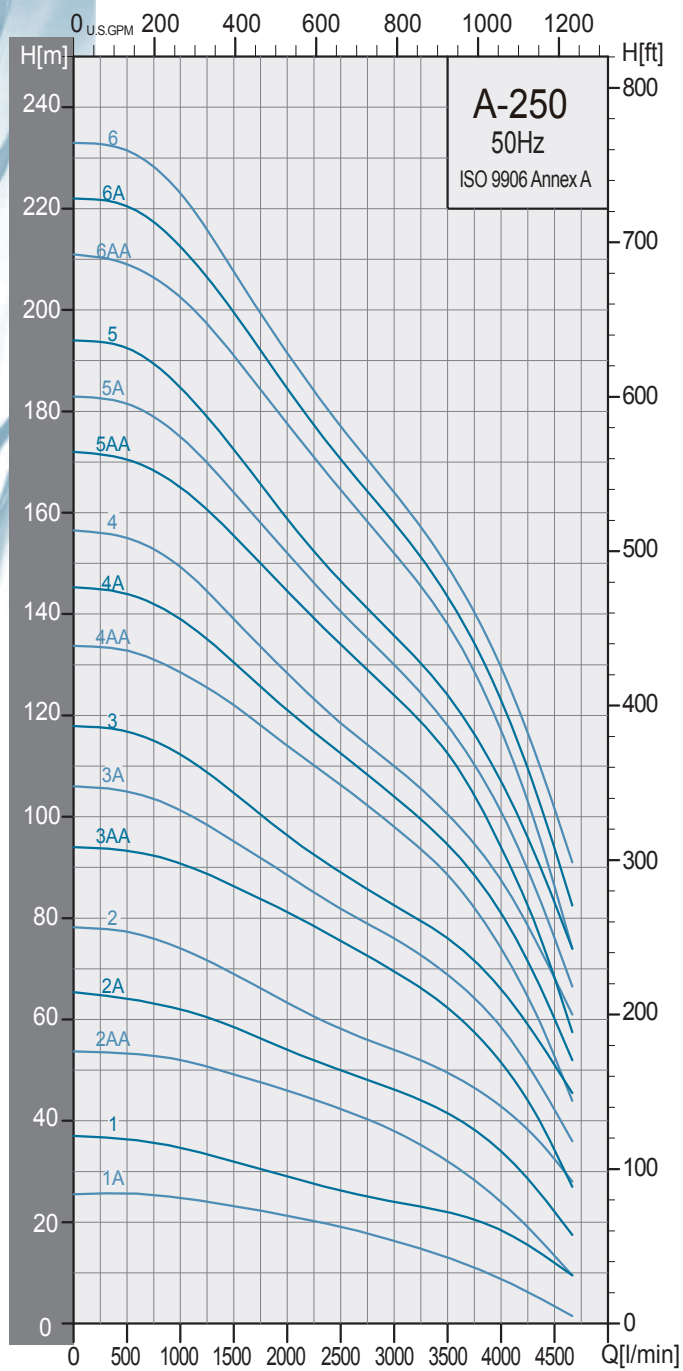

Selection Chart

50Hz Dimensions and weights

Pump Type	Motor		Q capacity 2850 rpm											
	P2		m³/h l/min	30	45	60	75	90	120	150	180	210	240	270
	KW	HP		500	750	1000	1250	1500	2000	2500	3000	3500	4000	4500
A 250-1-A	15	20	HEAD IN METERS	26	25.5	25	24	23	21	19	16	13	9	4
A 250-1	18.5	25		36.5	36	35	33	32	29	26	24	22	18	12
A 250-2-AA	30	40		53	52.5	52	50	49	46	42	38	32	24	14
A 250-2-A	37	50		64	63	62	60	58	54	50	46	41	34	22
A 250-2	45	60		77	76	74	71	69	63	58	54	49	42	32
A 250-3-AA	55	75		93	92	90	88	86	81	75	69	62	51	34
A 250-3-A	55	75		105	103	101	98	95	88	82	76	69	58	42
A 250-3	63	85		117	115	112	108	104	96	89	82	76	66	51
A 250-4-AA	75	100		133	131	128	125	122	114	106	98	88	74	53
A 250-4-A	75	100		144	142	139	135	130	121	112	104	94	81	60
A 250-4	75	100		155	152	149	144	139	128	118	110	100	87	68
A 250-5-AA	93	125		170	168	165	160	155	144	134	124	112	94	68
A 250-5-A	93	125		181	179	175	170	164	152	140	130	118	101	76
A 250-5	93	125		192	189	184	179	172	159	146	135	124	107	83
A 250-6-AA	110	150		209	206	202	197	191	178	164	152	138	117	86
A 250-6-A	110	150		220	217	212	206	199	184	170	158	143	123	93
A 250-6	110	150		231	228	223	216	207	191	177	164	149	129	101
A 250-7-AA	132	175		251	248	243	236	229	213	198	184	167	143	108
A 250-7-A	132	175		262	259	253	246	238	220	204	189	173	149	116
A 250-7	132	175		274	270	264	255	246	227	210	196	180	156	124
A 250-8-AA	147	200	292	288	282	274	266	247	230	213	195	168	128	
A 250-8-A	147	200	303	299	293	284	275	255	236	219	201	174	136	
A 250-8	147	200	315	310	303	294	284	262	243	225	207	181	144	
A 250-9-AA	170	230	331	327	320	312	302	281	260	242	221	191	146	
A 250-9-A	170	230	343	338	331	321	311	288	267	248	227	197	155	
A 250-9	170	230	354	349	341	331	319	295	273	254	233	204	162	

Pump Type	Motor Dia.	Dimensions (mm)			Net Weight (Kg) Pump
		A	C*	C**	
A 250-1-A	6"	772	237	241	46.1
A 250-1	6"	772	237	241	46.1
A 250-2-AA	6"	948	237	241	56.1
A 250-2-A	6"	948	237	241	56.1
A 250-2	8"	948	237	241	55.8
A 250-3-AA	8"	1124	237	241	65.6
A 250-3-A	8"	1124	237	241	65.6
A 250-3	8"	1124	237	241	65.6
A 250-4-AA	8"	1300	237	241	75.4
A 250-4-A	8"	1300	237	241	75.4
A 250-4	8"	1300	237	241	75.4
A 250-5-AA	8"	1476	237	241	85.8
A 250-5-A	8"	1476	237	241	85.8
A 250-5	8"	1476	237	241	85.8
A 250-6-AA	8"	1652	237	241	96.2
A 250-6-A	8"	1652	237	241	96.2
A 250-6	8"	1652	237	241	96.2
A 250-7-AA	10"	1828	262	274	111.2
A 250-7-A	10"	1828	262	274	111.2
A 250-7	10"	1828	262	274	111.2
A 250-8-AA	10"	2004	262	274	121.5
A 250-8-A	10"	2004	262	274	121.5
A 250-8	10"	2004	262	274	121.5
A 250-9-AA	10"	2180	262	274	131.7
A 250-9-A	10"	2180	262	274	131.7
A 250-9	10"	2180	262	274	131.7

C*: Maximum diameter of pump with one motor cable
 C**: Maximum diameter of pump with two motor cable
 - : On Request

